



Servicios Industriales
DEL PACÍFICO

2023 CATÁLOGO Perforación

BROGAS DE ACERO
ALTA VELOCIDAD

Sierrata Bimetálica Acero M3

Usada para hacer orificios en piezas de trabajo
Para usarse en taladro utilizando un mandril para sierratas
Fabricada en acero M3
Ideal para trabajar en aluminio, PVC, madera y plástico



Dientes de gran dureza



Ranura para extracción de residuos



Caja * Blister

Mandril para Sierrata

Usado para adaptar las sierratas al taladro perforando primero el centro del orificio que cortará la sierrata



Esquema



Blister

Código	Zanco	Para sierratas de
SGT-3000	1/4"	9/16" a 1-3/16" / 14-30 mm (SGT-2080 a SGT-2180)
SGT-3010	3/8"	9/16" a 1-3/16" / 14-30 mm (SGT-2080 a SGT-2180)
SGT-3020	3/8"	1-1/4" a 8-17/64" / 31-210 mm (SGT-2190 a SGT-2510)
SGT-3030	7/16"	1-1/4" a 8-17/64" / 31-210 mm (SGT-2190 a SGT-2510)

Juego de Sierrata Bimetálica

Estuche de plástico resistente

Incluye:
6 sierratas:
7/8" (SGT-2130), 1-1/8" (SGT-2170),
1-3/8" (SGT-2210), 1-3/4" (SGT-2270),
2" (SGT-2290) y 2-1/2" (SGT-2350)
2 mandriles:
3/8" (SGT-3010) y 7/16" (SGT-3030)
1 adaptador



Estuche

Código	Contenido
SGT-4010	1 juego de 9 piezas

PERFORACIÓN

Código	Diámetro	Mandril compatible	MIN	CAJA	Código	Diámetro	Mandril compatible	MIN	CAJA
*SGT-2080	9/16"	SGT-3000, SGT-3010	1	90	*SGT-2290	2"	SGT-3020, SGT-3030	1	36
*SGT-2090	5/8"	SGT-3000, SGT-3010	1	90	*SGT-2300	2-1/16"	SGT-3020, SGT-3030	1	30
*SGT-2100	11/16"	SGT-3000, SGT-3010	1	90	*SGT-2310	2-1/8"	SGT-3020, SGT-3030	1	30
*SGT-2110	3/4"	SGT-3000, SGT-3010	1	90	*SGT-2320	2-1/4"	SGT-3020, SGT-3030	1	30
SGT-2115	23/32"	SGT-3000, SGT-3010	1	90	*SGT-2330	2-5/16"	SGT-3020, SGT-3030	1	30
*SGT-2120	13/16"	SGT-3000, SGT-3010	1	90	SGT-2340	2-3/8"	SGT-3020, SGT-3030	1	30
*SGT-2130	7/8"	SGT-3000, SGT-3010	1	90	*SGT-2350	2-1/2"	SGT-3020, SGT-3030	1	30
*SGT-2140	15/16"	SGT-3000, SGT-3010	1	90	SGT-2355	2-9/16"	SGT-3020, SGT-3030	1	30
*SGT-2150	1"	SGT-3000, SGT-3010	1	90	*SGT-2360	2-5/8"	SGT-3020, SGT-3030	1	30
*SGT-2160	1-1/16"	SGT-3000, SGT-3010	1	60	SGT-2370	2-3/4"	SGT-3020, SGT-3030	1	21
*SGT-2170	1-1/8"	SGT-3000, SGT-3010	1	60	*SGT-2380	2-7/8"	SGT-3020, SGT-3030	1	21
*SGT-2180	1-3/16"	SGT-3000, SGT-3010	1	60	*SGT-2390	3"	SGT-3020, SGT-3030	1	21
*SGT-2190	1-1/4"	SGT-3020, SGT-3030	1	60	SGT-2400	3-1/8"	SGT-3020, SGT-3030	1	21
*SGT-2200	1-5/16"	SGT-3020, SGT-3030	1	60	SGT-2410	3-1/4"	SGT-3020, SGT-3030	1	21
*SGT-2210	1-3/8"	SGT-3020, SGT-3030	1	60	SGT-2420	3-3/8"	SGT-3020, SGT-3030	1	12
*SGT-2220	1-7/16"	SGT-3020, SGT-3030	1	60	SGT-2430	3-1/2"	SGT-3020, SGT-3030	1	12
*SGT-2230	1-1/2"	SGT-3020, SGT-3030	1	60	*SGT-2440	3-3/4"	SGT-3020, SGT-3030	1	12
SGT-2240	1-9/16"	SGT-3020, SGT-3030	1	36	SGT-2450	4"	SGT-3020, SGT-3030	1	12
*SGT-2250	1-5/8"	SGT-3020, SGT-3030	1	36	*SGT-2460	4-1/4"	SGT-3020, SGT-3030	1	9
*SGT-2260	1-11/16"	SGT-3020, SGT-3030	1	36	SGT-2470	4-1/2"	SGT-3020, SGT-3030	1	9
*SGT-2270	1-3/4"	SGT-3020, SGT-3030	1	36	SGT-2480	4-3/4"	SGT-3020, SGT-3030	1	9
SGT-2275	1.77"	SGT-3020, SGT-3030	1	36	SGT-2490	5"	SGT-3020, SGT-3030	1	6
*SGT-2280	1-7/8"	SGT-3020, SGT-3030	1	36	SGT-2500	5-1/2"	SGT-3020, SGT-3030	1	6
*SGT-2285	1.97"	SGT-3020, SGT-3030	1	36	SGT-2510	6"	SGT-3020, SGT-3030	1	6

SIERRATA BIMETÁLICA VELOCIDADES RECOMENDADAS

Medida	Longitud			Acero templado	Acero y acero inoxidable	Hierro fundido	Latón	Aluminio	Madera
	Pulgadas	Milímetros	Pies	RPM	RPM	RPM	RPM	RPM	RPM
9/16	14	0.147	580	300	400	790	900	3000	
5/8	16	0.164	550	275	365	730	825	3000	
11/16	17	0.180	500	250	330	665	750	3000	
3/4	19	0.196	460	230	300	600	690	3000	
13/16	21	0.213	425	210	290	580	660	3000	
7/8	22	0.229	390	195	260	520	585	3000	
1	25	0.262	350	175	235	470	525	2700	
1-1/16	27	0.278	325	160	215	435	480	2700	
1-1/8	29	0.295	300	150	200	400	450	2700	
1-3/16	30	0.311	285	145	190	380	425	2400	
1-1/4	32	0.327	275	140	180	360	410	2400	
1-5/16	33	0.344	260	135	175	345	390	2400	
1-3/8	35	0.360	250	125	165	330	375	2400	
1-7/16	37	0.376	240	120	160	315	360	2400	
1-1/2	38	0.393	230	115	150	300	345	2400	
1-9/16	40	0.409	220	110	145	290	330	2100	
1-5/8	41	0.425	210	105	140	280	315	2100	
1-1/6	43	0.442	205	100	135	270	305	2100	
1-3/4	44	0.458	195	95	130	260	295	2100	
1-3/16	46	0.475	190	95	125	250	285	2100	
1-7/8	48	0.491	180	90	120	240	270	2100	
2	51	0.524	170	85	115	230	255	2000	
2-1/16	52	0.54	165	80	110	220	245	2000	
2-1/8	54	0.556	160	80	105	210	240	2000	
2-1/4	57	0.589	150	75	100	200	225	2000	
2-5/16	59	0.605	145	75	95	195	225	2000	

Medida	Longitud			Acero templado	Acero y acero inoxidable	Hierro fundido	Latón	Aluminio	Madera
	Pulgadas	Milímetros	Pies	RPM	RPM	RPM	RPM	RPM	RPM
2-5/8	60	0.622	140	70	90	190	220	2000	
2-1/2	64	0.655	135	65	85	180	205	1850	
2-9/16	65	0.671	130	65	85	175	200	1850	
2-5/8	67	0.687	130	65	85	170	195	1800	
2-11/16	68	0.704	130	65	80	170	190	1800	
2-3/4	70	0.72	125	60	80	160	185	1800	
2-7/8	73	0.753	120	60	75	160	180	1800	
3	76	0.785	115	55	70	150	170	1800	
3-1/8	79	0.818	110	55	70	140	165	1500	
3-1/4	83	0.851	105	50	65	140	155	1500	
3-3/8	86	0.884	100	50	65	130	150	1500	
3-1/2	89	0.916	95	45	60	130	145	1200	
3-5/8	92	0.949	90	45	60	120	140	1200	
3-3/4	95	0.982	90	45	60	120	135	1200	
3-7/8	98	1.014	90	45	60	120	135	1200	
4	102	1.047	85	40	55	110	130	1000	
4-1/8	105	1.08	80	40	55	110	120	1000	
4-1/4	108	1.113	80	40	55	110	120	900	
4-3/8	111	1.145	80	40	50	100	120	900	
4-1/2	114	1.178	75	35	50	100	105	900	
4-3/4	121	1.244	75	35	50	92	95	900	
5	127	1.309	65	30	45	90	90	800	
5-1/2	140	1.44	60	25	40	85	85	800	
5-3/4	146	1.505	55	25	35	75	75	800	
6	152	1.571	55	25	35	75	75	800	

Broca para Concreto Punta de Carburo

Alto rendimiento
Zanco recto



Punta de carburo



Bolsa de PVC colgante

Código	Diámetro	Largo	Zanco
ST-5-150-10000	1/8"	3"	1/8"
ST-5-150-10002	5/32"	3"	5/32"
ST-5-150-10003	5/32"	3-1/2"	5/32"
ST-5-150-10004	3/16"	3"	3/16"
ST-5-150-10005	3/16"	4"	3/16"
ST-5-150-10010	1/4"	4"	1/4"
ST-5-150-10020	1/4"	6"	1/4"
ST-5-150-10030	1/4"	12"	1/4"
ST-5-150-10040	5/16"	4"	5/16"
ST-5-150-10050	5/16"	6"	5/16"
ST-5-150-10060	5/16"	12"	5/16"
ST-5-150-10070	3/8"	4"	3/8"
ST-5-150-10080	7/16"	6"	3/8"
ST-5-150-10090	3/8"	6"	3/8"
ST-5-150-10100	3/8"	12"	3/8"
ST-5-150-10110	1/2"	4"	3/8"
ST-5-150-10120	1/2"	6"	3/8"
ST-5-150-10130	1/2"	12"	3/8"
ST-5-150-10140	5/8"	6"	1/2"
ST-5-150-10145	5/8"	12"	1/2"
ST-5-150-10150	3/4"	6"	1/2"
ST-5-150-10155	3/4"	12"	1/2"
ST-5-150-10160	7/8"	6"	1/2"
ST-5-150-10165	7/8"	12"	1/2"
ST-5-150-10170	1"	6"	1/2"
ST-5-150-10185	1"	12"	1/2"

Broca para Concreto Punta de Carburo

Alto rendimiento



ANSI



Punta de carburo



Bolsa de PVC

Código	Diámetro	Largo	Largo de corte	MIN	CAJA
ST-5-148-001	1/8"	3"	3/4"	1	10
ST-5-148-010	5/32"	3"	1-3/8"	1	10
ST-5-148-020	3/16"	4"	1-3/4"	1	10
ST-5-148-030	1/4"	4"	2-3/8"	1	10
ST-5-148-040	1/4"	6"	4-3/8"	1	10
ST-5-148-050	1/4"	12"	10"	1	10
ST-5-148-060	5/16"	4"	3-3/16"	1	10
ST-5-148-070	5/16"	6"	4-3/8"	1	10
ST-5-148-080	5/16"	12"	10"	1	10
ST-5-148-090	3/8"	4"	3-3/16"	1	10
ST-5-148-100	3/8"	6"	4-3/8"	1	10
ST-5-148-110	3/8"	12"	10"	1	10
ST-5-148-120	1/2"	6"	4-3/8"	1	5
ST-5-148-130	1/2"	12"	10"	1	5
ST-5-148-140	5/8"	6"	4-3/8"	1	5
ST-5-148-150	5/8"	12"	10"	1	5
ST-5-148-160	3/4"	6"	4-3/8"	1	5
ST-5-148-170	3/4"	12"	10"	1	5
ST-5-148-180	7/8"	6"	4-3/4"	1	5
ST-5-148-190	7/8"	12"	10"	1	5
ST-5-148-200	1"	6"	4-3/4"	1	5
ST-5-148-210	1"	12"	10"	1	5

Broca para Concreto SDS Plus Punta de Carburo

Compatible SDS Plus



Punta de carburo



Zanco

Bolsa de PVC colgante

Código	Diámetro	Largo
ST-5-151-050	1/4"	4"
ST-5-151-100	1/4"	6"
ST-5-151-150	1/4"	13"
ST-5-151-200	5/16"	6"
ST-5-151-250	5/16"	13"
ST-5-151-300	3/8"	6"
ST-5-151-350	3/8"	13"
ST-5-151-375	3/8"	18"
ST-5-151-400	1/2"	6"
ST-5-151-450	1/2"	13"
ST-5-151-475	1/2"	18"
ST-5-151-500	5/8"	6"
ST-5-151-550	5/8"	13"
ST-5-151-575	5/8"	18"
ST-5-151-600	3/4"	6"
ST-5-151-650	3/4"	13"
ST-5-151-675	3/4"	18"
ST-5-151-678	7/8"	18"
ST-5-151-700	1"	6"
ST-5-151-750	1"	13"
ST-5-151-775	1"	18"

Broca para Concreto SDS Plus Punta de Carburo

Compatible SDS Plus
Punta autocentrante permite una penetración precisa
Ángulo de punta 160°
Flauta cuadrada
Efecto de cincelado para romper concreto
Rápida perforación



ANSI



Punta de carburo



160°

Zanco

Caballote

Código	Diámetro	Largo	Largo de corte
ST-5-148-300	1/4"	4"	2"
ST-5-148-310	1/4"	6"	4"
ST-5-148-315	1/4"	8"	6"
ST-5-148-320	1/4"	12"	10"
ST-5-148-330	5/16"	6"	4"
ST-5-148-340	5/16"	12"	10"
ST-5-148-350	3/8"	6"	4"
ST-5-148-360	3/8"	12"	10"
ST-5-148-370	1/2"	6"	4"
ST-5-148-380	1/2"	12"	10"
ST-5-148-390	5/8"	6"	4"
ST-5-148-400	5/8"	12"	10"
ST-5-148-410	3/4"	6"	4"
ST-5-148-420	3/4"	12"	10"
ST-5-148-430	7/8"	12"	10"
ST-5-148-440	1"	12"	10"

Broca para Concreto SDS Plus Punta de Carburo

Compatible SDS Plus
Punta autocentrante permite una penetración precisa
Ángulo de punta 130°
Flauta cuadrada
Efecto de cincelado para romper concreto
Rápida perforación



Punta de carburo



130°

Zanco

Caballote

Código	Diámetro	Largo	Largo de corte
ST-5-148-310-M	1/4"	6"	4"
ST-5-148-320-M	1/4"	12"	10"
ST-5-148-330-M	5/16"	6"	4"
ST-5-148-340-M	5/16"	12"	10"
ST-5-148-350-M	3/8"	6"	4"
ST-5-148-360-M	3/8"	12"	10"
ST-5-148-370-M	1/2"	6"	4"
ST-5-148-380-M	1/2"	12"	10"

Broca para Concreto 3 Cortes SDS Plus Punta de Carburo

Compatible SDS Plus
Punta autocentrante permite una penetración precisa
3 aristas de corte
Efecto de cincelado para romper concreto
Rápida perforación



ANSI



Punta de carburo



Zanco

Caballote

Código	Diámetro	Largo	Largo de corte
ST-5-148-500	1/4"	6"	4"
ST-5-148-520	1/4"	12"	10"
ST-5-148-540	5/16"	6"	4"
ST-5-148-560	5/16"	12"	10"
ST-5-148-580	3/8"	6"	4"
ST-5-148-600	3/8"	12"	10"
ST-5-148-620	1/2"	6"	4"
ST-5-148-640	1/2"	12"	10"
ST-5-148-660	5/8"	6"	4"
ST-5-148-680	5/8"	12"	10"
ST-5-148-700	3/4"	12"	10"



PERFORACIÓN

PERFORACIÓN

Broca para Concreto 3 Cortes SDS Plus Punta de Carburo

Compatible SDS Plus
Punta autocentrante permite una penetración precisa
3 aristas de corte
Efecto de cincelado para romper concreto
Rápida perforación



Código	Diámetro	Largo	Largo de corte
ST-5-148-500-M	1/4"	6"	4"
ST-5-148-520-M	1/4"	12"	10"
ST-5-148-540-M	5/16"	6"	4"
ST-5-148-560-M	5/16"	12"	10"
ST-5-148-580-M	3/8"	6"	4"
ST-5-148-600-M	3/8"	12"	10"
ST-5-148-620-M	1/2"	6"	4"
ST-5-148-640-M	1/2"	12"	10"



Broca para Concreto 6 Cortes SDS MAX Punta de Carburo

Compatible SDS MAX
Punta de carburo monobloc con punta autocentrante
Ángulo de punta 135°
6 aristas de corte
Flauta cuadrada
Para usarse en hormigón armado, ladrillo, hormigón y bloque



Código	Diámetro	Largo	Largo de corte
ST-5-148-920	5/8"	13"	8"
ST-5-148-925	5/8"	21"	16"
ST-5-148-930	3/4"	13"	8"
ST-5-148-935	3/4"	21"	16"
ST-5-148-940	7/8"	13"	8"
ST-5-148-945	7/8"	21"	16"
ST-5-148-950	1"	13"	8"
ST-5-148-955	1"	21"	16"



Broca para Concreto Sand Blastada

Calidad industrial



Código	Diámetro	Largo
ST-5-149-10005	3/16"	4"
ST-5-149-10100	3/8"	12"

Exhibidor de Brocas y Cinceles SDS

Especial para montar sobre panel ranurado o perfoel (NO INCLUYE PANEL RANURADO)

Material: PTR de 3/4"

Acabado: pintura en color negro mate con electrostático

Incluye rótulos de la marca Weston Tools® con códigos, medidas y códigos de barra y 60 ganchos de alambroón de 1/8", con medidas de 8 cm x 3/4"

Medidas: 80 cm de ancho y soportes de 8, 15 y 25 cm de profundidad

Exhibidor exclusivo para artículos Weston Tools®



Ejemplo de exhibidor montado en panel ranurado



Gancho para panel perfoel o ranurado

Código	Descripción
EX-SDS	Paquete de brocas y cinceles SDS con exhibidor para punto de venta. Preguntar a tu asesor de ventas.



Broca AAV Punta de Carburo

Medida zanco: 1/2" (12.7 mm)

Punta de carburo de tungsteno y zanco de acero alta velocidad

Ángulo de punta 118°

Corte a la derecha

Zanco reducido de 1/2"

Para uso en materiales no ferrosos (cobre, aluminio, estaño, níquel, etc.)

Para uso en materiales no metálicos (madera, plásticos duros, cerámica, etc.)

No utilizarse en acero inoxidable



Código	Medida
ST-5-149-10200	1/8"
ST-5-149-10210	9/64"
ST-5-149-10220	5/32"
ST-5-149-10230	3/16"
ST-5-149-10240	13/64"
ST-5-149-10250	7/32"
ST-5-149-10260	1/4"
ST-5-149-10270	9/32"
ST-5-149-10280	5/16"
ST-5-149-10290	11/32"
ST-5-149-10300	3/8"
ST-5-149-10310	7/16"
ST-5-149-10320	1/2"

**TAMBIÉN
CONTAMOS CON:**

CINCELES SDS

Ver página 100





Broca Zanco Recto AAV



Uso general

Cuerpo de acero de alta velocidad

Recubrimiento óxido negro y dorado produce menor fricción, previene oxidación y desgaste

Ángulo de punta 118°

Zanco recto

Para perforar acero, hierro, acero inoxidable, madera y plástico



118°



AAV



Bolsa de PVC

DISPONIBLE:
Juego de Brocas ST-5-159-010
VER PÁG. 136



Código	Diámetro	Diámetro decimal	Largo	Largo de corte	MIN
ST-5-154-020	1/16"	0.0625"	1-7/8"	7/8"	10
ST-5-154-025	5/64"	0.0781"	2"	1"	10
ST-5-154-030	3/32"	0.0938"	2-1/4"	1-1/4"	10
ST-5-154-035	7/64"	0.1094"	2-5/8"	1-1/2"	10
ST-5-154-040	1/8"	0.125"	2-3/4"	1-5/8"	10
ST-5-154-045	9/64"	0.1406"	2-7/8"	1-3/4"	10
ST-5-154-050	5/32"	0.1562"	3-1/8"	2"	10
ST-5-154-055	11/64"	0.1719"	3-1/4"	2-1/8"	10
ST-5-154-060	3/16"	0.1875"	3-1/2"	2-5/16"	10
ST-5-154-065	13/64"	0.2031"	3-5/8"	2-7/16"	10
ST-5-154-070	7/32"	0.2188"	3-3/4"	2-1/2"	10
ST-5-154-075	15/64"	0.2344"	3-7/8"	2-5/8"	10
ST-5-154-080	1/4"	0.25"	4"	2-3/4"	10
ST-5-154-085	17/64"	0.2656"	4-1/8"	2-7/8"	10
ST-5-154-090	9/32"	0.2812"	4-1/4"	2-15/16"	10
ST-5-154-095	19/64"	0.2969"	4-3/8"	3-1/16"	10
ST-5-154-100	5/16"	0.3125"	4-1/2"	3-3/16"	5
ST-5-154-105	21/64"	0.3281"	4-5/8"	3-5/16"	5
ST-5-154-110	11/32"	0.34382"	4-3/4"	3-7/16"	5
ST-5-154-115	23/64"	0.3594"	4-7/8"	3-1/2"	5
ST-5-154-120	3/8"	0.375"	5"	3-5/8"	5
ST-5-154-125	25/64"	0.3906"	5-1/8"	3-3/4"	5
ST-5-154-130	13/32"	0.4062"	5-1/4"	3-7/8"	5
ST-5-154-135	27/64"	0.4219"	5-3/8"	3-15/16"	5
ST-5-154-140	7/16"	0.4375"	5-1/2"	4-1/16"	5
ST-5-154-145	29/64"	0.4531"	5-5/8"	4-3/16"	5
ST-5-154-150	15/32"	0.4688"	5-3/4"	4-5/16"	5
ST-5-154-155	31/64"	0.4844"	5-7/8"	4-3/8"	5
ST-5-154-160	1/2"	0.5"	6"	4-1/2"	5

Exhibidor de Brocas AAV - M2 Zanco recto

Ideal para exhibición en punto de venta

Medidas: 38 x 40 x 36 cm

Material: cuerpo y charolas de acrílico

Exhibidor exclusivo para artículos Weston Tools®

Incluye rótulos de la marca Weston Tools®, charolas marcadas con su medida, almacenamiento inferior, medidor de brocas, cerradura y 2 llaves



Charolas marcadas con su medida



Almacenamiento interior



Medidor de brocas

DISPONIBLE:
Exhibidor de Brocas AAV-M2 y Zanco 1/2"
VER PÁG. 137



Código	Descripción
EX-BROCA2PAQ	Paquete de brocas zanco recto AAV - M2 de 1/16" a 1/2" con exhibidor para punto de venta. Pregunta a tu asesor de ventas.

RECUBRIMIENTOS DE BROCAS



AAV



TiN



Co

AAV Acero Alta Velocidad

Uso general, en la mayoría de los metales como el acero, hierro fundido o piezas forjadas.

TiN Recubrimiento de Titanio

Acabado oro brillante. Con recubrimiento muy duro, el cual incrementa la velocidad de corte de 25% a 35%.

Co Cobalto

Tiene la capacidad de trabajar velocidades 30% mayores que las de brocas convencionales. De alta velocidad. Perfora todo tipo de materiales.

PERFORACIÓN

Broca Zanco Recto

Uso industrial
 Ángulo de punta 118°
 Corte a la derecha
 Zanco recto
 Para perforar acero, madera y plástico



118°

Sobre de cartón
 ♦ MIN: 12
 ● MIN: 6

AAV **TIN** **Co**

Fraccional

AAV - M2	Cobalto	Diámetro	Diámetro decimal	Largo total	Largo de corte
♦ ST-5-160-005		1/64"	0.0156"	3/4"	3/16"
♦ ST-5-160-010		1/32"	0.0312"	1-3/8"	1/2"
♦ ST-5-160-015		3/64"	0.0469"	1-3/4"	3/4"
♦ ST-5-160-020	♦ ST-5-162-005	1/16"	0.0625"	1-7/8"	7/8"
♦ ST-5-160-025	♦ ST-5-162-010	5/64"	0.0781"	2"	1"
♦ ST-5-160-030	♦ ST-5-162-015	3/32"	0.0938"	2-1/4"	1-1/4"
♦ ST-5-160-035	♦ ST-5-162-020	7/64"	0.1094"	2-5/8"	1-1/2"
♦ ST-5-160-040	♦ ST-5-162-025	1/8"	0.1250"	2-3/4"	1-5/8"
♦ ST-5-160-045	♦ ST-5-162-030	9/64"	0.1406"	2-7/8"	1-3/4"
♦ ST-5-160-050	♦ ST-5-162-035	5/32"	0.1562"	3-1/8"	2"
♦ ST-5-160-055	♦ ST-5-162-040	11/64"	0.1719"	3-1/4"	2-1/8"
♦ ST-5-160-060	♦ ST-5-162-045	3/16"	0.1875"	3-1/2"	2-5/16"
♦ ST-5-160-065	♦ ST-5-162-050	13/64"	0.2031"	3-5/8"	2-7/16"
♦ ST-5-160-070	♦ ST-5-162-055	7/32"	0.2188"	3-3/4"	2-1/2"
♦ ST-5-160-075	♦ ST-5-162-060	15/64"	0.2344"	3-7/8"	2-5/8"
♦ ST-5-160-080	♦ ST-5-162-065	1/4"	0.2500"	4"	2-3/4"
♦ ST-5-160-085	♦ ST-5-162-070	17/64"	0.2656"	4-1/8"	2-7/8"
♦ ST-5-160-090	♦ ST-5-162-075	9/32"	0.2812"	4-1/4"	2-15/16"
♦ ST-5-160-095	♦ ST-5-162-080	19/64"	0.2969"	4-3/8"	3-1/16"
♦ ST-5-160-100	♦ ST-5-162-085	5/16"	0.3125"	4-1/2"	3-3/16"
♦ ST-5-160-105	♦ ST-5-162-090	21/64"	0.3281"	4-5/8"	3-5/16"
♦ ST-5-160-110	♦ ST-5-162-095	11/32"	0.3438"	4-3/4"	3-7/16"
♦ ST-5-160-115	♦ ST-5-162-100	23/64"	0.3594"	4-7/8"	3-1/2"
♦ ST-5-160-120	♦ ST-5-162-105	3/8"	0.3750"	5"	3-5/8"
♦ ST-5-160-125	♦ ST-5-162-110	25/64"	0.3906"	5-1/8"	3-3/4"
♦ ST-5-160-130	♦ ST-5-162-115	13/32"	0.4062"	5-1/4"	3-7/8"
♦ ST-5-160-135	♦ ST-5-162-120	27/64"	0.4219"	5-3/8"	3-15/16"
♦ ST-5-160-140	♦ ST-5-162-125	7/16"	0.4375"	5-1/2"	4-1/16"
♦ ST-5-160-145	♦ ST-5-162-130	29/64"	0.4531"	5-5/8"	4-3/16"
♦ ST-5-160-150	♦ ST-5-162-135	15/32"	0.4688"	5-3/4"	4-5/16"
♦ ST-5-160-155	♦ ST-5-162-140	31/64"	0.4844"	5-7/8"	4-3/8"
♦ ST-5-160-160	♦ ST-5-162-145	1/2"	0.5000"	6"	4-1/2"
♦ ST-5-160-165		33/64"	0.5156"	6-5/8"	4-13/16"
♦ ST-5-160-170	♦ ST-5-162-170	17/32"	0.5312"	6-5/8"	4-13/16"
♦ ST-5-160-175		35/64"	0.5469"	6-5/8"	4-13/16"
♦ ST-5-160-180	♦ ST-5-162-180	9/16"	0.5625"	6-5/8"	4-13/16"
♦ ST-5-160-185		37/64"	0.5781"	6-5/8"	4-13/16"
♦ ST-5-160-190		19/32"	0.5938"	7-1/8"	5-3/16"
♦ ST-5-160-195		39/64"	0.6094"	7-1/8"	5-3/16"
♦ ST-5-160-200		5/8"	0.6250"	7-1/8"	5-3/16"
♦ ST-5-160-205		41/64"	0.6406"	7-1/8"	5-3/16"
♦ ST-5-160-210		21/32"	0.6562"	7-1/8"	5-3/16"
♦ ST-5-160-215		43/64"	0.6719"	7-5/8"	5-5/8"
♦ ST-5-160-220		11/16"	0.6875"	7-5/8"	5-5/8"
♦ ST-5-160-225		45/64"	0.7031"	7-5/8"	5-5/8"
♦ ST-5-160-230		23/32"	0.7188"	7-5/8"	5-5/8"
♦ ST-5-160-235		47/64"	0.7344"	7-5/8"	5-5/8"
♦ ST-5-160-240		3/4"	0.7500"	7-5/8"	5-5/8"

Métrica

AAV - M2	Cobalto	Diámetro	Largo total	Largo de corte
♦ ST-5-163-005		0.35 mm	19 mm	4 mm
♦ ST-5-163-008		0.50 mm	22 mm	6 mm
♦ ST-5-163-009		0.75 mm	28 mm	9 mm
♦ ST-5-163-010	♦ ST-5-162-300	1.00 mm	34 mm	12 mm
♦ ST-5-163-015		1.05 mm	34 mm	12 mm
♦ ST-5-163-017		1.10 mm	36 mm	14 mm
♦ ST-5-163-020		1.15 mm	36 mm	14 mm
♦ ST-5-163-022		1.20 mm	38 mm	16 mm
♦ ST-5-163-025		1.25 mm	38 mm	16 mm
♦ ST-5-163-028		1.40 mm	40 mm	18 mm
♦ ST-5-163-030		1.45 mm	40 mm	18 mm
♦ ST-5-163-035	♦ ST-5-162-305	1.50 mm	40 mm	18 mm
♦ ST-5-163-037		1.60 mm	43 mm	20 mm
♦ ST-5-163-040		1.75 mm	46 mm	22 mm
♦ ST-5-163-045		1.80 mm	46 mm	22 mm
♦ ST-5-163-050		1.85 mm	46 mm	22 mm
♦ ST-5-163-053		1.90 mm	46 mm	22 mm
♦ ST-5-163-055	♦ ST-5-162-310	2.00 mm	49 mm	24 mm

AAV - M2	Titanio	Cobalto	Diámetro	Largo total	Largo de corte
♦ ST-5-163-060			2.05 mm	49 mm	24 mm
♦ ST-5-163-062			2.20 mm	53 mm	27 mm
♦ ST-5-163-063			2.25 mm	53 mm	27 mm
♦ ST-5-163-064			2.40 mm	57 mm	30 mm
♦ ST-5-163-065		♦ ST-5-162-315	2.50 mm	57 mm	30 mm
♦ ST-5-163-070			2.60 mm	57 mm	30 mm
♦ ST-5-163-072			2.70 mm	61 mm	33 mm
♦ ST-5-163-075			2.75 mm	61 mm	33 mm
♦ ST-5-163-080			2.90 mm	61 mm	33 mm
♦ ST-5-163-085	♦ ST-5-169-005	♦ ST-5-162-320	3.00 mm	61 mm	33 mm
♦ ST-5-163-086			3.00 mm	61 mm	33 mm
♦ ST-5-163-090	♦ ST-5-162-325		3.20 mm	65 mm	36 mm
♦ ST-5-163-093	♦ ST-5-162-330		3.25 mm	65 mm	36 mm
♦ ST-5-163-095			3.30 mm	65 mm	36 mm
♦ ST-5-163-097	♦ ST-5-162-335		3.40 mm	70 mm	39 mm
♦ ST-5-163-100	♦ ST-5-162-340		3.50 mm	70 mm	39 mm
♦ ST-5-163-103			3.70 mm	70 mm	39 mm
♦ ST-5-163-105	♦ ST-5-162-345		3.75 mm	73 mm	43 mm
♦ ST-5-163-108			3.90 mm	75 mm	43 mm
♦ ST-5-163-110	♦ ST-5-162-350		4.00 mm	75 mm	43 mm
♦ ST-5-163-115	♦ ST-5-162-355		4.20 mm	75 mm	43 mm
♦ ST-5-163-117			4.25 mm	80 mm	47 mm
♦ ST-5-163-120	♦ ST-5-162-365		4.30 mm	80 mm	47 mm
♦ ST-5-163-125			4.40 mm	80 mm	47 mm
♦ ST-5-163-130	♦ ST-5-162-370		4.50 mm	80 mm	47 mm
♦ ST-5-163-135	♦ ST-5-162-375		4.75 mm	82 mm	47 mm
♦ ST-5-163-140			4.80 mm	86 mm	52 mm
♦ ST-5-163-145			4.90 mm	86 mm	52 mm
♦ ST-5-163-150	♦ ST-5-162-380		5.00 mm	86 mm	52 mm
♦ ST-5-163-154			5.20 mm	86 mm	52 mm
♦ ST-5-163-155			5.25 mm	92 mm	53 mm
♦ ST-5-163-160	♦ ST-5-162-385		5.50 mm	93 mm	57 mm
♦ ST-5-163-165			5.60 mm	93 mm	57 mm
♦ ST-5-163-167			5.70 mm	93 mm	57 mm
♦ ST-5-163-170			5.75 mm	93 mm	57 mm
♦ ST-5-163-175			5.90 mm	93 mm	57 mm
♦ ST-5-163-180	♦ ST-5-162-390		6.00 mm	93 mm	57 mm
♦ ST-5-163-185			6.10 mm	101 mm	63 mm
♦ ST-5-163-186			6.25 mm	101 mm	63 mm
♦ ST-5-163-188			6.40 mm	101 mm	63 mm
♦ ST-5-163-190	♦ ST-5-162-395		6.50 mm	101 mm	63 mm
♦ ST-5-163-195			6.60 mm	101 mm	63 mm
♦ ST-5-163-198			6.65 mm	101 mm	63 mm
♦ ST-5-163-200			6.70 mm	101 mm	63 mm
♦ ST-5-163-203			6.75 mm	101 mm	63 mm
♦ ST-5-163-205			6.80 mm	109 mm	69 mm
♦ ST-5-163-210	♦ ST-5-162-400		7.00 mm	109 mm	69 mm
♦ ST-5-163-213			7.10 mm	109 mm	69 mm
♦ ST-5-163-215			7.20 mm	109 mm	69 mm
♦ ST-5-163-217			7.25 mm	109 mm	69 mm
♦ ST-5-163-220	♦ ST-5-162-405		7.50 mm	109 mm	69 mm
♦ ST-5-163-222			7.70 mm	114 mm	75 mm
♦ ST-5-163-223			7.80 mm	117 mm	75 mm
♦ ST-5-163-225			7.90 mm	117 mm	75 mm
♦ ST-5-163-230	♦ ST-5-162-410		8.00 mm	117 mm	75 mm
♦ ST-5-163-233			8.25 mm	117 mm	75 mm
♦ ST-5-163-235	♦ ST-5-162-415		8.50 mm	117 mm	75 mm
♦ ST-5-163-238			8.60 mm	121 mm	79 mm
♦ ST-5-163-238-3			8.75 mm	125 mm	81 mm
♦ ST-5-163-239			8.90 mm	125 mm	81 mm
♦ ST-5-163-240	♦ ST-5-162-420		9.00 mm	125 mm	81 mm
♦ ST-5-163-243			9.25 mm	125 mm	81 mm
♦ ST-5-163-245	♦ ST-5-162-425		9.50 mm	125 mm	81 mm
♦ ST-5-163-247			9.60 mm	130 mm	86 mm
♦ ST-5-163-248			9.75 mm	133 mm	87 mm
♦ ST-5-163-250	♦ ST-5-162-430		10.00 mm	133 mm	87 mm
♦ ST-5-163-255			10.20 mm	133 mm	87 mm
♦ ST-5-163-257			10.25 mm	133 mm	87 mm
♦ ST-5-163-260	♦ ST-5-162-435		10.50 mm	133 mm	87 mm
♦ ST-5-163-263			10.75 mm	142 mm	94 mm
♦ ST-5-163-265	♦ ST-5-162-440		11.00 mm	142 mm	94 mm
♦ ST-5-163-267			11.25 mm	142 mm	94 mm
♦ ST-5-163-270	♦ ST-5-162-445		11.50 mm	142 mm	94 mm
♦ ST-5-163-273			11.75 mm	142 mm	94 mm
♦ ST-5-163-275	♦ ST-5-162-450		12.00 mm	151 mm	101 mm
♦ ST-5-163-277			12.25 mm	151 mm	101 mm
♦ ST-5-163-280	♦ ST-5-162-455		12.50 mm	151 mm	101 mm
♦ ST-5-163-283			12.75 mm	151 mm	101 mm
♦ ST-5-163-285	♦ ST-5-162-460		13.00 mm	151 mm	101 mm
♦ ST-5-163-287			13.25 mm	160 mm	101 mm
♦ ST-5-163-288			13.50 mm	160 mm	108 mm
♦ ST-5-163-290			14.00 mm	160 mm	108 mm
♦ ST-5-163-293			14.50 mm	169 mm	114 mm
♦ ST-5-163-295			15.00 mm	169 mm	114 mm
♦ ST-5-163-300			15.50 mm	178 mm	120 mm

Broca Zanco Recto AAV - M2

Ángulo de punta 118°

Corte a la derecha

Zanco recto

Para uso en materiales de alta dureza, aluminio, aleación de cobre



Sobre de cartón

Numérica

Código	#	Diámetro decimal	Largo total	Largo de corte	MIN
ST-5-170-005	1	0.2280"	3-7/8"	2-5/8"	12
ST-5-170-010	2	0.2210"	3-7/8"	2-5/8"	12
ST-5-170-015	3	0.2130"	3-3/4"	2-1/2"	12
ST-5-170-020	4	0.2090"	3-3/4"	2-1/2"	12
ST-5-170-025	5	0.2055"	3-3/4"	2-1/2"	12
ST-5-170-030	6	0.2040"	3-3/4"	2-1/2"	12
ST-5-170-035	7	0.2010"	3-5/8"	2-7/16"	12
ST-5-170-040	8	0.1990"	3-5/8"	2-7/16"	12
ST-5-170-045	9	0.1960"	3-5/8"	2-7/16"	12
ST-5-170-050	10	0.1935"	3-5/8"	2-7/16"	12
ST-5-170-055	11	0.1910"	3-1/2"	2-5/16"	12
ST-5-170-060	12	0.1890"	3-1/2"	2-5/16"	12
ST-5-170-065	13	0.1850"	3-1/2"	2-5/16"	12
ST-5-170-070	14	0.1820"	3-3/8"	2-3/16"	12
ST-5-170-075	15	0.1800"	3-3/8"	2-3/16"	12
ST-5-170-080	16	0.1770"	3-3/8"	2-3/16"	12
ST-5-170-085	17	0.1730"	3-3/8"	2-3/16"	12
ST-5-170-090	18	0.1695"	3-1/4"	2-1/8"	12
ST-5-170-095	19	0.1660"	3-1/4"	2-1/8"	12
ST-5-170-100	20	0.1610"	3-1/4"	2-1/8"	12
ST-5-170-105	21	0.1590"	3-1/4"	2-1/8"	12
ST-5-170-110	22	0.1570"	3-1/8"	2"	12
ST-5-170-115	23	0.1540"	3-1/8"	2"	12
ST-5-170-120	24	0.1520"	3-1/8"	2"	12
ST-5-170-125	25	0.1495"	3"	1-7/8"	12
ST-5-170-130	26	0.1470"	3"	1-7/8"	12
ST-5-170-135	27	0.1440"	3"	1-7/8"	12
ST-5-170-140	28	0.1405"	2-7/8"	1-3/4"	12
ST-5-170-145	29	0.1360"	2-7/8"	1-3/4"	12
ST-5-170-150	30	0.1285"	2-3/4"	1-5/8"	12
ST-5-170-155	31	0.1200"	2-3/4"	1-5/8"	12
ST-5-170-160	32	0.1160"	2-3/4"	1-5/8"	12
ST-5-170-165	33	0.1130"	2-5/8"	1-1/2"	12
ST-5-170-170	34	0.1110"	2-5/8"	1-1/2"	12
ST-5-170-175	35	0.1100"	2-5/8"	1-1/2"	12
ST-5-170-180	36	0.1065"	2-1/2"	1-7/16"	12
ST-5-170-185	37	0.1040"	2-1/2"	1-7/16"	12
ST-5-170-190	38	0.1015"	2-1/2"	1-7/16"	12
ST-5-170-195	39	0.0995"	2-3/8"	1-3/8"	12
ST-5-170-200	40	0.0980"	2-3/8"	1-3/8"	12
ST-5-170-205	41	0.0960"	2-3/8"	1-3/8"	12
ST-5-170-210	42	0.0935"	2-1/4"	1-1/4"	12
ST-5-170-215	43	0.0890"	2-1/4"	1-1/4"	12
ST-5-170-220	44	0.0860"	2-1/8"	1-1/8"	12
ST-5-170-225	45	0.0820"	2-1/8"	1-1/8"	12
ST-5-170-230	46	0.0810"	2-1/8"	1-1/8"	12
ST-5-170-235	47	0.0785"	2"	1"	12
ST-5-170-240	48	0.0760"	2"	1"	12
ST-5-170-245	49	0.0730"	2"	1"	12

Código	#	Diámetro decimal	Largo total	Largo de corte	MIN
ST-5-170-250	50	0.0700"	2"	1"	12
ST-5-170-255	51	0.0760"	2"	1"	12
ST-5-170-260	52	0.0635"	1-7/8"	7/8"	12
ST-5-170-265	53	0.0595"	1-7/8"	7/8"	12
ST-5-170-270	54	0.0550"	1-7/8"	7/8"	12
ST-5-170-275	55	0.0520"	1-7/8"	7/8"	12
ST-5-170-280	56	0.0465"	1-3/4"	3/4"	12
ST-5-170-285	57	0.0430"	1-3/4"	3/4"	12
ST-5-170-290	58	0.0420"	1-5/8"	11/16"	12
ST-5-170-295	59	0.0410"	1-5/8"	11/16"	12
ST-5-170-300	60	0.0400"	1-5/8"	11/16"	12
ST-5-170-310	61	0.0390"	1-5/8"	11/16"	12
ST-5-170-320	62	0.0380"	1-1/2"	5/8"	12
ST-5-170-330	63	0.0370"	1-1/2"	5/8"	12
ST-5-170-340	64	0.0360"	1-1/2"	5/8"	12
ST-5-170-350	65	0.0350"	1-1/2"	5/8"	12
ST-5-170-360	66	0.0330"	1-3/8"	1/2"	12
ST-5-170-370	67	0.0320"	1-3/8"	1/2"	12
ST-5-170-380	68	0.0310"	1-3/8"	1/2"	12
ST-5-170-390	69	0.0292"	1-3/8"	1/2"	12
ST-5-170-400	70	0.0280"	1-1/4"	3/8"	12
ST-5-170-410	71	0.0260"	1-1/4"	3/8"	12
ST-5-170-420	72	0.0250"	1-1/8"	5/16"	12
ST-5-170-430	73	0.0240"	1-1/8"	5/16"	12
ST-5-170-440	74	0.0225"	1"	1/4"	12
ST-5-170-450	75	0.0210"	1"	1/4"	12
ST-5-170-460	76	0.0200"	7/8"	3/16"	12
ST-5-170-470	77	0.0180"	7/8"	3/16"	12
ST-5-170-480	78	0.0160"	7/8"	3/16"	12
ST-5-170-490	79	0.0145"	3/4"	1/8"	12
ST-5-170-500	80	0.0135"	3/4"	1/8"	12

Alfabética

Código	Medida	Diámetro decimal	Largo total	Largo de corte	MIN
ST-5-180-005	A	0.2240"	3-7/8"	2-5/8"	12
ST-5-180-010	B	0.2380"	4"	2-3/4"	12
ST-5-180-015	C	0.2420"	4"	2-3/4"	12
ST-5-180-020	D	0.2460"	4"	2-3/4"	12
ST-5-180-025	E	0.2500"	4"	2-3/4"	12
ST-5-180-030	F	0.2570"	4-1/8"	2-7/8"	6
ST-5-180-035	G	0.2610"	4-1/8"	2-7/8"	6
ST-5-180-040	H	0.2660"	4-1/8"	2-7/8"	6
ST-5-180-045	I	0.2720"	4-1/8"	2-7/8"	6
ST-5-180-050	J	0.2770"	4-1/8"	2-7/8"	6
ST-5-180-055	K	0.2810"	4-1/4"	2-15/16"	6
ST-5-180-060	L	0.2900"	4-1/4"	2-15/16"	6
ST-5-180-065	M	0.2950"	4-3/8"	3-1/16"	6
ST-5-180-070	N	0.3020"	4-3/8"	3-1/16"	6
ST-5-180-075	O	0.3160"	4-1/2"	3-3/16"	6
ST-5-180-080	P	0.3230"	4-5/8"	3-5/16"	6
ST-5-180-085	Q	0.3320"	4-3/4"	3-7/16"	6
ST-5-180-090	R	0.3390"	4-3/4"	3-7/16"	6
ST-5-180-095	S	0.3480"	4-7/8"	3-1/2"	6
ST-5-180-100	T	0.3580"	4-7/8"	3-1/2"	6
ST-5-180-105	U	0.3680"	5"	3-5/8"	6
ST-5-180-110	V	0.3770"	5"	3-5/8"	6
ST-5-180-115	W	0.3860"	5-1/8"	3-3/4"	6
ST-5-180-120	X	0.3970"	5-1/8"	3-3/4"	6
ST-5-180-125	Y	0.4040"	5-1/4"	3-7/8"	6
ST-5-180-130	Z	0.4130"	5-1/4"	3-7/8"	6

**TAMBIÉN
CONTAMOS CON:**

BROQUEROS



Ver página 219

Juego de Brocas Zanco Recto AAV

Uso general
Cuerpo de acero de alta velocidad
Recubrimiento óxido negro y dorado produce menor fricción, previene oxidación y desgaste
Ángulo de punta 118°
Zanco recto
Incluye estuche organizador con medidas identificadas, fabricado en plástico resistente a golpes y agua



AAV



Estuche plástico colgante



Código	Piezas	Tipo	Medidas
ST-5-159-010	29	Fraccional	1/16" a 1/2"

Juego de Brocas Zanco Recto AAV Fraccionales, Alfabéticas, Numéricas y Métricas

Ángulo de punta 118°
Fraccional: incremento en 64avos
Métrica: incremento en 0.5 mm
Para uso en materiales de alta dureza, aluminio y aleación de cobre
Incluye estuche



Estuche plástico colgante



Código	Piezas	Tipo	Medidas
ST-5-159-001	115	Fraccional	1/16" a 1/2"
		Alfabética	A a Z
		Númérica	#1 a #60
ST-5-159-003	13	Fraccional	1/16" a 1/4"
ST-5-159-004	29	Fraccional	1/16" a 1/2"
ST-5-159-008	25	Métrica	1 a 13 mm
ST-5-170-525	60	Númérica	#1 a #60
ST-5-180-500	26	Alfabética	A a Z

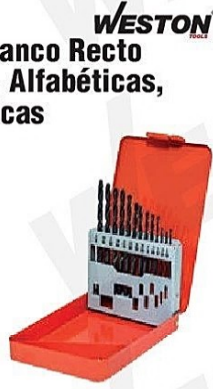

AAV



Estuche plástico colgante Estuche metálico colgante

Juego de Brocas Zanco Recto de Cobalto

Ángulo de punta 118°
Fraccional: incremento en 64avos
Métrica: incremento en 0.5 mm
Para uso en materiales de alta dureza, aluminio y aleación de cobre
Incluye estuche



ST-5-159-006



Estuche plástico colgante



Co



Estuche metálico colgante



Código	Piezas	Tipo	Medidas
ST-5-159-006	29	Fraccional	1/16" a 1/2"
ST-5-159-009	25	Métrica	1 a 13 mm

Broca Larga AAV de 12"

Fabricada en Acero de Alta Velocidad
Punta en ángulo de 118°
Corte a la derecha
Zanco recto
Templada y rectificada
Para acero, fundición, materiales ferrosos y no ferrosos



AAV



Código	Medida	Diámetro Decimal	Largo total	Largo de corte
ST-5-165-005	1/8"	0.1250"	12"	9"
ST-5-165-010	9/64"	0.1406"	12"	9"
ST-5-165-015	5/32"	0.1562"	12"	9"
ST-5-165-020	11/64"	0.1719"	12"	9"
ST-5-165-025	3/16"	0.1875"	12"	9"
ST-5-165-030	13/64"	0.2031"	12"	9"
ST-5-165-033	7/32"	0.2188"	12"	9"
ST-5-165-035	15/64"	0.2344"	12"	9"
ST-5-165-040	1/4"	0.2500"	12"	9"
ST-5-165-043	17/64"	0.2656"	12"	9"
ST-5-165-044	9/32"	0.2812"	12"	9"
ST-5-165-045	5/16"	0.1929"	12"	9"
ST-5-165-050	21/64"	0.1968"	12"	9"
ST-5-165-055	11/32"	0.2969"	12"	9"
ST-5-165-060	23/64"	0.3125"	12"	9"
ST-5-165-065	3/8"	0.3281"	12"	9"
ST-5-165-080	7/16"	0.4375"	12"	9"
ST-5-165-085	29/64"	0.4531"	12"	9"
ST-5-165-090	15/32"	0.4688"	12"	9"
ST-5-165-100	1/2"	0.5000"	12"	9"
ST-5-165-102	17/32"	0.5312"	12"	9"
ST-5-165-105	9/16"	0.5625"	12"	9"
ST-5-165-110	19/32"	0.5938"	12"	9"
ST-5-165-115	5/8"	0.6250"	12"	9"
ST-5-165-120	11/16"	0.6875"	12"	9"
ST-5-165-122	3/4"	0.7500"	12"	9"
ST-5-165-130	13/16"	0.8125"	12"	9"

Broca Extra Larga AAV de 18"

Fabricada en Acero de Alta Velocidad
Punta en ángulo de 118°
Corte a la derecha
Zanco recto
Templada y rectificada
Para acero, fundición, materiales ferrosos y no ferrosos



AAV



Código	Medida	Diámetro decimal	Largo total	Largo de corte
ST-5-168-005	3/16"	0.1875"	18"	13"
ST-5-168-010	1/4"	0.2500"	18"	13"
ST-5-168-015	7/32"	0.2188"	18"	13"
ST-5-168-020	5/16"	0.3125"	18"	13"
ST-5-168-030	3/8"	0.3750"	18"	13"
ST-5-168-035	7/16"	0.4375"	18"	13"
ST-5-168-040	15/32"	0.4688"	18"	13"
ST-5-168-045	1/2"	0.5000"	18"	13"

Broca Larga TL AAV

Fabricada en Acero de Alta Velocidad
Punta en ángulo de 118°
Corte a la derecha
Zanco recto



AAV

Código	Medida	Diámetro decimal	Largo total	Largo de corte
ST-5-164-005	5/64"	0.0781"	3-3/4"	2"
ST-5-164-010	7/64"	0.1094"	4-3/4"	2-1/2"
ST-5-164-013	7/64"	0.1094"	8"	5-1/2"
ST-5-164-015	1/8"	0.1250"	5-1/8"	2-3/4"
ST-5-164-020	9/64"	0.1406"	5-3/8"	3"
ST-5-164-025	5/32"	0.1562"	5-3/8"	3"
ST-5-164-030	11/64"	0.1719"	5-3/4"	3-3/8"
ST-5-164-035	3/16"	0.1875"	5-3/4"	3-3/8"
ST-5-164-040	13/64"	0.2031"	6"	3-5/8"
ST-5-164-045	7/32"	0.2188"	6"	3-5/8"
ST-5-164-050	1/4"	0.2500"	6-1/8"	3-3/4"
ST-5-164-055	17/64"	0.2656"	6-1/8"	3-3/4"
ST-5-164-060	9/32"	0.2812"	6-1/4"	3-7/8"
ST-5-164-065	19/64"	0.2969"	6-3/8"	4"
ST-5-164-070	5/16"	0.3125"	6-3/8"	4"
ST-5-164-075	21/64"	0.3281"	6-1/2"	4-1/8"
ST-5-164-080	11/32"	0.3438"	6-1/2"	4-1/8"
ST-5-164-085	23/64"	0.3594"	6-7/8"	4-1/4"
ST-5-164-090	3/8"	0.3750"	6-3/4"	4-1/4"
ST-5-164-095	27/64"	0.4219"	7-1/16"	5-1/32"
ST-5-164-100	7/16"	0.4375"	7-1/4"	4-5/8"
ST-5-164-105	29/64"	0.4531"	7-11/16"	5-1/32"
ST-5-164-110	15/32"	0.4688"	7-1/2"	4-3/4"
ST-5-164-115	31/64"	0.4844"	7-3/4"	4-3/4"
ST-5-164-120	1/2"	0.5000"	7-3/4"	4-3/4"
ST-5-164-125	17/32"	0.5312"	8"	4-3/4"
ST-5-164-135	9/16"	0.5625"	8-1/4"	4-7/8"
ST-5-164-137	5/8"	0.6250"	8-3/4"	4-7/8"
ST-5-164-140	39/64"	0.6094"	8-3/4"	4-7/8"
ST-5-164-145	41/64"	0.6406"	7-1/4"	4-5/8"
ST-5-164-150	43/64"	0.6719"	7-3/4"	4-3/4"
ST-5-164-153	11/16"	0.6875"	9-1/4"	5-3/8"
ST-5-164-154	45/64"	0.7031"	9-1/2"	5-5/8"
ST-5-164-155	23/32"	0.7188"	9-1/2"	5-5/8"
ST-5-164-156	47/64"	0.7344"	10"	6-1/8"
ST-5-164-160	3/4"	0.7500"	9-3/4"	5-7/8"
ST-5-164-163	13/16"	0.8125"	10"	6-1/8"
ST-5-164-165	53/64"	0.8281"	10-1/4"	6-1/8"
ST-5-164-175	57/64"	0.8906"	10-1/4"	6-1/8"
ST-5-164-186	63/64"	0.9843"	11"	-

Broca Zanco Reducido de 1/2" y 3/4" AAV Fraccional

Ángulo de punta 118°

Corte a la derecha

Para uso en materiales de alta dureza

Ideal para realizar cambios de herramienta sin ajustes ni calibraciones



Zanco



WESTON



AAV

Co



Tubo plástico

AAV	Cobalto	Medida	Diámetro decimal	Largo total	Largo de corte	Zanco
ST-5-166-010		33/64"	0.5156"	6"	3"	1/2"
ST-5-166-015	ST-5-167-300	17/32"	0.5312"	6"	3"	1/2"
ST-5-166-020		35/64"	0.5469"	6"	3"	1/2"
ST-5-166-025	ST-5-167-320	9/16"	0.5625"	6"	3"	1/2"
ST-5-166-030		37/64"	0.5781"	6"	3"	1/2"
ST-5-166-035	ST-5-167-340	19/32"	0.5938"	6"	3"	1/2"
ST-5-166-040		39/64"	0.6094"	6"	3"	1/2"
ST-5-166-045	ST-5-167-360	5/8"	0.6250"	6"	3"	1/2"
ST-5-166-050		41/64"	0.6406"	6"	3"	1/2"
ST-5-166-055	ST-5-167-380	21/32"	0.6562"	6"	3"	1/2"
ST-5-166-060		43/64"	0.6719"	6"	3"	1/2"
ST-5-166-065	ST-5-167-400	11/16"	0.6870"	6"	3"	1/2"
ST-5-166-070		45/64"	0.7031"	6"	3"	1/2"
ST-5-166-075	ST-5-167-420	23/32"	0.7188"	6"	3"	1/2"
ST-5-166-080		47/64"	0.7344"	6"	3"	1/2"
ST-5-166-085	ST-5-167-440	3/4"	0.7500"	6"	3"	1/2"
ST-5-166-090		49/64"	0.7656"	6"	3"	1/2"
ST-5-166-095	ST-5-167-460	25/32"	0.7812"	6"	3"	1/2"
ST-5-166-100		51/64"	0.7969"	6"	3"	1/2"
ST-5-166-105	ST-5-167-480	13/16"	0.8125"	6"	3"	1/2"
ST-5-166-110		53/64"	0.8281"	6"	3"	1/2"
ST-5-166-115	ST-5-167-500	27/32"	0.8438"	6"	3"	1/2"
ST-5-166-120		55/64"	0.8594"	6"	3"	1/2"
ST-5-166-125	ST-5-167-520	7/8"	0.8750"	6"	3"	1/2"
ST-5-166-130		57/64"	0.8906"	6"	3"	1/2"
ST-5-166-135		29/32"	0.9062"	6"	3"	1/2"
ST-5-166-140		59/64"	0.9219"	6"	3"	1/2"
ST-5-166-145	ST-5-167-540	15/16"	0.9375"	6"	3"	1/2"
ST-5-166-150		61/64"	0.9531"	6"	3"	1/2"
ST-5-166-155		31/32"	0.9688"	6"	3"	1/2"
ST-5-166-160		63/64"	0.9844"	6"	3"	1/2"
ST-5-166-165	ST-5-167-560	1"	1.0000"	6"	3"	1/2"
ST-5-166-166		1-1/64"	1.0156"	6"	3"	1/2"
ST-5-166-167		1-1/32"	1.0312"	6"	3"	1/2"
ST-5-166-170		1-1/16"	1.0625"	6"	3"	1/2"
ST-5-166-175		1-3/32"	1.0938"	6"	3"	1/2"
ST-5-166-180	ST-5-167-580	1-1/8"	1.1250"	6"	3"	1/2"
ST-5-166-185		1-5/32"	1.1562"	6"	3"	1/2"
ST-5-166-190		1-3/16"	1.1875"	6"	3"	1/2"
ST-5-166-195		1-7/32"	1.2188"	6"	3"	1/2"
ST-5-166-200	ST-5-167-600	1-1/4"	1.2500"	6"	3"	1/2"
ST-5-166-205		1-5/16"	1.3125"	6"	3"	1/2"
ST-5-166-210	ST-5-167-620	1-3/8"	1.3750"	6"	3"	1/2"
ST-5-166-215		1-13/32"	1.4062"	6"	3"	1/2"
ST-5-166-220		1-7/16"	1.4375"	6"	3"	1/2"
ST-5-166-225	ST-5-167-640	1-1/2"	1.5000"	6"	3"	1/2"
ST-5-166-230		1-9/16"	1.5625"	6"	3"	3/4"
ST-5-166-235		1-5/8"	1.6250"	6"	3"	3/4"
ST-5-166-240		1-3/4"	1.7500"	6"	3"	3/4"
ST-5-166-245		1-7/8"	1.8750"	6"	3"	3/4"
ST-5-166-250		2"	2.0000"	6"	3"	3/4"

Broca Zanco Reducido de 1/2" AAV Métrica

Zanco recto de 1/2"

Ángulo de punta 118°

Corte a la derecha

Para uso en materiales de alta dureza

Ideal para realizar cambios de herramienta sin ajustes ni calibraciones



Zanco

WESTON



AAV

Co



Tubo plástico

Código	Medida	Diámetro decimal	Largo total	Largo de corte
ST-5-166-260	13.0mm	0.5118"	6"	3"
ST-5-166-265	13.5mm	0.5315"	6"	3"
ST-5-166-270	14.0mm	0.5512"	6"	3"
ST-5-166-275	14.5mm	0.5709"	6"	3"
ST-5-166-280	15.0mm	0.5906"	6"	3"
ST-5-166-285	15.5mm	0.6102"	6"	3"
ST-5-166-290	16.0mm	0.6299"	6"	3"
ST-5-166-295	16.5mm	0.6496"	6"	3"
ST-5-166-300	17.0mm	0.6693"	6"	3"
ST-5-166-305	17.5mm	0.6890"	6"	3"
ST-5-166-310	18.0mm	0.7087"	6"	3"
ST-5-166-315	18.5mm	0.7283"	6"	3"
ST-5-166-320	19.0mm	0.7480"	6"	3"
ST-5-166-325	19.5mm	0.7677"	6"	3"
ST-5-166-330	20.0mm	0.7874"	6"	3"
ST-5-166-335	20.5mm	0.8071"	6"	3"
ST-5-166-340	21.0mm	0.8268"	6"	3"
ST-5-166-345	21.5mm	0.8465"	6"	3"
ST-5-166-350	22.0mm	0.8661"	6"	3"
ST-5-166-355	22.5mm	0.8858"	6"	3"
ST-5-166-360	23.0mm	0.9055"	6"	3"
ST-5-166-365	23.5mm	0.9252"	6"	3"
ST-5-166-370	24.0mm	0.9449"	6"	3"
ST-5-166-375	24.5mm	0.9646"	6"	3"
ST-5-166-380	25.0mm	0.9843"	6"	3"

Exhibidor de Brocas AAV - M2 Zanco Recto y Zanco de 1/2"

Ideal para exhibición en punto de venta

Medidas: Ø25 cm x 60 cm alto

Material: cuerpo y repisas de acrílico

Incluye: rótulos de la marca Weston Tools®, almacenamiento inferior, cerradura y 2 llaves

Exhibidor exclusivo para artículos Weston Tools®



Medidas de brocas



Almacenamiento inferior



Juego de Brocas de AAV Zanco de 1/2"

Uso general

Incluye estuche

Zanco de 1/2"



WESTON



AAV

Co

Estuche metálico

Código	Piezas	Tipo	Medidas
ST-5-159-025	8	Fraccional	9/16", 5/8", 11/16", 3/4", 13/16", 7/8", 15/16", 1"

DISPONIBLE

Exhibidor de Brocas AAV - M2 Zanco Recto VER PÁG. 133

Código Descripción

EX-BROCA2PAQ Paquete de brocas zanco recto AAV - M2 de 1/16" a 1/2" y top 8 de brocas zanco de 1/2" con exhibidor para punto de venta. Pregunta a tu asesor de ventas.

Broca AAV - M2 Zanco Cónico

Fabricadas con acero alta velocidad M2
Acabado pavonado negro
Punta en ángulo de 118°
Corte a la derecha



Fraccional

Código	Diámetro	Zanco	Largo de corte	Largo total
ST-5-190-120	3/8"	#1	84 mm	174 mm
ST-5-190-140	7/16"	#1	92 mm	187 mm
ST-5-190-150	15/32"	#1	99 mm	193 mm
ST-5-190-160	1/2"	#2	101 mm	213 mm
ST-5-190-165	33/64"	#2	107 mm	220 mm
ST-5-190-170	17/32"	#2	107 mm	220 mm
ST-5-190-175	35/64"	#2	114 mm	226 mm
ST-5-190-180	9/16"	#2	114 mm	226 mm
ST-5-190-185	37/64"	#2	114 mm	226 mm
ST-5-190-190	19/32"	#2	114 mm	227 mm
ST-5-190-195	39/64"	#2	114 mm	227 mm
ST-5-190-200	5/8"	#2	114 mm	227 mm
ST-5-190-210	21/32"	#2	120 mm	234 mm
ST-5-190-215	43/64"	#2	127 mm	240 mm
ST-5-190-220	11/16"	#2	127 mm	240 mm
ST-5-190-222	23/32"	#2	133 mm	246 mm
ST-5-190-225	3/4"	#2	140 mm	253 mm
ST-5-190-227	49/64"	#2	143 mm	257 mm
ST-5-190-230	25/32"	#2	143 mm	257 mm
ST-5-190-235	51/64"	#3	147 mm	279 mm
ST-5-190-240	13/16"	#3	147 mm	279 mm
ST-5-190-245	53/64"	#3	147 mm	279 mm
ST-5-190-250	27/32"	#3	147 mm	279 mm
ST-5-190-255	55/64"	#3	147 mm	279 mm
ST-5-190-260	7/8"	#3	147 mm	280 mm
ST-5-190-265	57/64"	#3	147 mm	280 mm
ST-5-190-270	29/32"	#3	147 mm	280 mm
ST-5-190-280	15/16"	#3	147 mm	280 mm
ST-5-190-290	31/32"	#3	154 mm	286 mm
ST-5-190-295	63/64"	#3	154 mm	286 mm
ST-5-190-300	1"	#3	154 mm	286 mm
ST-5-190-302	1-1/32"	#3	157 mm	290 mm
ST-5-190-303	1 3/64"	#3	160 mm	293 mm
ST-5-190-304	1-1/16"	#3	160 mm	293 mm
ST-5-190-306	1 7/64"	#3	180 mm	304 mm
ST-5-190-307	1 7/64"	#4	168 mm	307 mm
ST-5-190-307-1	1-1/8"	#3	163 mm	304 mm
ST-5-190-308	1-1/8"	#4	168 mm	331 mm
ST-5-190-310	1-5/32"	#4	175 mm	336 mm
ST-5-190-311	1-11/64"	#4	177 mm	337 mm
ST-5-190-312	1-3/16"	#4	177 mm	337 mm
ST-5-190-314	1-7/32"	#4	180 mm	340 mm
ST-5-190-315	1-1/4"	#4	190 mm	350 mm



Broca de Centro AAV

Fabricada en Acero de Alta Velocidad
Para acero, fundición, materiales ferrosos y no ferrosos



Tubo plástico



Tubo plástico

Código	Diámetro	Zanco	Largo de corte	Largo total
ST-5-190-316	1-1/4"	#3	163 mm	304 mm
ST-5-190-317	1-17/64"	#4	207 mm	367 mm
ST-5-190-318	1-9/32"	#4	207 mm	367 mm
ST-5-190-319	1-19/64"	#4	210 mm	370 mm
ST-5-190-320	1-5/16"	#4	210 mm	370 mm
ST-5-190-321	1-21/64"	#4	210 mm	373 mm
ST-5-190-322	1-11/32"	#4	210 mm	373 mm
ST-5-190-323	1-23/64"	#4	213 mm	376 mm
ST-5-190-324	1-3/8"	#4	213 mm	376 mm
ST-5-190-325	1-25/64"	#4	218 mm	380 mm
ST-5-190-326	1-13/32"	#4	218 mm	380 mm
ST-5-190-327	1-27/64"	#4	220 mm	384 mm
ST-5-190-328	1-7/16"	#4	220 mm	384 mm
ST-5-190-331	1-31/64"	#4	226 mm	390 mm
ST-5-190-332	1-1/2"	#4	226 mm	390 mm
ST-5-190-336	1-9/16"	#4	189 mm	361 mm
ST-5-190-339	1-39/64"	#4	243 mm	408 mm
ST-5-190-340	1-5/8"	#4	196 mm	368 mm
ST-5-190-342	1-5/8"	#5	241 mm	445 mm
ST-5-190-348	1-3/4"	#4	254 mm	426 mm
ST-5-190-352	1-13/16"	#4	207 mm	379 mm
ST-5-190-356	1-7/8"	#4	210 mm	383 mm
ST-5-190-357	1-29/32"	#4	211 mm	383 mm
ST-5-190-358	1-7/8"	#5	244 mm	455 mm
ST-5-190-360	1-15/16"	#5	244 mm	455 mm
ST-5-190-362	1-31/32"	#5	244 mm	456 mm
ST-5-190-363	1-63/64"	#5	244 mm	456 mm
ST-5-190-400	2"	#5	244 mm	456 mm
ST-5-190-402	2-1/32"	#5	240 mm	456 mm
ST-5-190-408	2-1/8"	#5	276 mm	456 mm
ST-5-190-414	2-7/32"	#5	238 mm	457 mm
ST-5-190-416	2-1/4"	#5	238 mm	458 mm
ST-5-190-420	2-5/16"	#5	238 mm	458 mm
ST-5-190-424	2-3/8"	#5	238 mm	458 mm
ST-5-190-432	2-1/2"	#5	268 mm	488 mm
ST-5-190-440	2-5/8"	#5	280 mm	508 mm
ST-5-190-448	2-3/4"	#5	303 mm	532 mm
ST-5-190-456	2-7/8"	#5	320 mm	552 mm
ST-5-190-500	3"	#5	337 mm	568 mm
ST-5-190-510	3"	#6	337 mm	568 mm

Código	#	Diámetro de cuerpo	Diámetro de punta	Largo Total
ST-8-600-010	1	1/8"	3/64"	3/4"
ST-8-600-015	2	3/16"	5/64"	5/64"
ST-8-600-020	3	1/4"	7/64"	7/64"
ST-8-600-025	4	5/16"	1/8"	1/8"
ST-8-600-030	5	7/16"	3/16"	3/16"
ST-8-600-035	6	1/2"	7/32"	7/32"
ST-8-600-040	7	5/8"	1/4"	1/4"
ST-8-600-045	8	3/4"	5/16"	5/16"

Broca de Centro Larga AAV

Fabricada en Acero de Alta Velocidad
Para acero, fundición, materiales ferrosos y no ferrosos



Punta



Tubo plástico

Código	#	Diámetro de cuerpo
ST-8-601-010	2	3"
ST-8-601-015	2	4"
ST-8-601-020	3	3"
ST-8-601-025	3	4"
ST-8-601-030	3	6"
ST-8-601-035	4	3"
ST-8-601-040	4	4"
ST-8-601-045	4	6"
ST-8-601-050	5	3"
ST-8-601-055	5	4"
ST-8-601-060	5	6"
ST-8-601-065	6	6"

Métrica

Código	Diámetro	Zanco	Largo de corte	Largo total
ST-5-191-191	12 mm	#1	91 mm	182 mm
ST-5-191-212	14 mm	#1	98 mm	189 mm
ST-5-191-215	15 mm	#2	99 mm	212 mm
ST-5-191-220	16 mm	#2	105 mm	218 mm
ST-5-191-228	18 mm	#2	115 mm	228 mm
ST-5-191-236	20 mm	#2	125 mm	238 mm
ST-5-191-2441	22 mm	#2	135 mm	248 mm

Código	Diámetro	Zanco	Largo de corte	Largo total
ST-5-191-252	24 mm	#3	140 mm	281 mm
ST-5-191-256	25 mm	#3	140 mm	281 mm
ST-5-191-260	26 mm	#3	145 mm	286 mm
ST-5-191-268	28 mm	#3	150 mm	291 mm
ST-5-191-276	30 mm	#3	155 mm	296 mm
ST-5-191-280	31 mm	#3	160 mm	301 mm
ST-5-191-284	32 mm	#4	160 mm	334 mm

TAMBIÉN CONTAMOS CON:

TORNOS



Ver página 210



Broca Escalonada AAV - M2

Punta split point: estabilidad y precisión de perforado
 Acero Alta Velocidad M2
 Acabado óxido negro
 Zanco 3/8"
 Ideal para trabajar con materiales de metal y plástico
 Diferentes diámetros de perforación en la sola broca

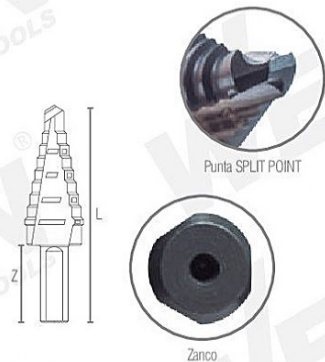

Punta SPLIT POINT

Zanco



Código	#	Rango de perforación	Tamaños	Largo total (L)	Largo de zanco (Z)	MN	CAJA	MASTER
ST-5-192-000	1	3/16" a 1/2"	6	57.01 mm	25 mm	1	6	48
ST-5-192-005	2	1/8" a 1/2"	13	86.02 mm	25 mm	1	6	48
ST-5-192-010	3	1/4" a 3/4"	9	70.44 mm	25 mm	1	6	48
ST-5-192-015	4	3/16" a 7/8"	12	80.91 mm	25 mm	1	3	48
ST-5-192-020	5	1/4" a 1-3/8"	10	70.46 mm	25 mm	1	3	48
ST-5-192-025	Juego de brocas escalonadas 4 piezas (#2, #3, #4, #5)							



Broca para Vidrio

Agua necesaria para el uso correcto de la herramienta
 Para perforar cerámica, vidrio



Punta de carburo



Bolsa de PVC colgante



Blister



Código	Diámetro	Largo	Largo de corte
ST-5-148-982	1/8"	3"	1-1/2"
ST-5-148-984	3/16"	3"	1-1/2"
ST-5-148-986	1/4"	4"	2-1/2"
ST-5-148-988	5/16"	4"	2-1/2"
ST-5-148-990	3/8"	4"	2-1/2"
ST-5-148-992	1/2"	4"	2-1/2"

PERFORACIÓN

Broca para Madera Tipo Espada

Largo total: 152 mm
 Zanco hexagonal de 1/4"
 Largo de zanco: 95 mm
 Punta que sirve como guía para mayor precisión en la perforación



Broca Forstner

Calidad industrial
 Para perforaciones limpias con fondo plano
 Para barrenar en maderas suaves, duras y plásticos



Punta



Código	Medida
ST-5-152-001	1/4"
ST-5-152-010	5/16"
ST-5-152-020	3/8"
ST-5-152-025	7/16"
ST-5-152-030	1/2"
ST-5-152-035	9/16"
ST-5-152-040	5/8"
ST-5-152-045	11/16"
ST-5-152-050	3/4"
ST-5-152-055	7/8"
ST-5-152-060	1"
ST-5-152-065	1-1/8"
ST-5-152-070	1-3/16"
ST-5-152-075	1-1/4"
ST-5-152-080	1-3/8"
ST-5-152-085	1-1/2"

Bolsa de PVC colgante



Broca Azul Multiusos

Corte de hélice con forma "S" para una buena evacuación de todas las virutas
 Ranura en ángulo de 118°
 Para usarse en acero aleado, cerámica y madera tierna
 Afilado positivo con punta centrante
 4 aristas afiladas
 Flauta en L
 Zanco recto
 Penetración limpia y rápida



Punta



118°

Bolsa de PVC colgante



Estuche plástico colgante

Código	Medida	Largo total	Largo de zanco	Ø Zanco
ST-5-152-090	3/4"	85 mm	70 mm	6.8 mm
ST-5-152-095	1"	82 mm	66 mm	8 mm
ST-5-152-096	1-1/8"	85 mm	70 mm	9.5 mm
ST-5-152-097	1-1/4"	85 mm	70 mm	9.5 mm
ST-5-152-100	1-3/8"	85 mm	70 mm	9.5 mm
ST-5-152-105	1-1/2"	85 mm	70 mm	9.5 mm
ST-5-152-110	2"	85 mm	70 mm	9.5 mm

Código	Diámetro	Largo	Largo de corte
ST-5-148-800	1/8"	2-1/2"	25/32"
ST-5-148-805	5/32"	3"	1-3/8"
ST-5-148-810	3/16"	3-1/2"	1-25/32"
ST-5-148-815	1/4"	4"	2-1/2"
ST-5-148-820	5/16"	4-1/2"	3"
ST-5-148-825	3/8"	4-1/2"	3"
ST-5-148-830	1/2"	6"	4"
ST-5-148-835	5/8"	6"	4"



WESTON CARBURO SÓLIDO

Broca Zanco Recto de Carburo

Grano de carburo sub-micrónico sólido C-2 grado premium con 10% Cobalto
Sin recubrimiento
Corte a la derecha
Zanco recto
Punta en ángulo de 118°
Tolerancia de diámetro: +0.0000/-0.0005
Recomendada para: aleaciones no ferrosas, hierro fundido, plásticos, aluminio y materiales altamente abrasivos

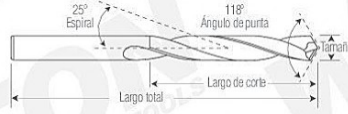

Fracional

Código	Diámetro	Largo de corte	Largo total
ST-1-160-005	1/64"	3/16"	1-1/4"
ST-1-160-010	1/32"	5/16"	1-1/4"
ST-1-160-015	3/64"	3/4"	1-1/2"
ST-1-160-020	1/16"	3/4"	1-1/2"
ST-1-160-025	5/64"	7/8"	1-3/4"
ST-1-160-030	3/32"	1"	2"
ST-1-160-035	7/64"	1-1/4"	2-1/4"
ST-1-160-040	1/8"	1-1/4"	2-1/4"
ST-1-160-045	9/64"	1-3/8"	2-1/2"
ST-1-160-050	5/32"	1-3/8"	2-1/2"
ST-1-160-055	11/64"	1-5/8"	2-3/4"
ST-1-160-060	3/16"	1-5/8"	2-3/4"
ST-1-160-065	13/64"	1-3/4"	3"
ST-1-160-070	7/32"	1-3/4"	3"
ST-1-160-075	15/64"	2"	3-1/4"
ST-1-160-080	1/4"	2"	3-1/4"
ST-1-160-085	17/64"	2-1/8"	3-1/2"
ST-1-160-090	9/32"	2-1/8"	3-1/2"
ST-1-160-095	19/64"	2-3/8"	3-3/4"
ST-1-160-100	5/16"	2-3/8"	3-3/4"
● ST-2-160-180	9/16"	-	-

Código	Diámetro	Largo de corte	Largo total
ST-1-160-105	11/32"	2-1/2"	4"
ST-1-160-110	3/8"	2-3/4"	4-1/4"
ST-1-160-115	7/16"	2-7/8"	4-1/2"
ST-1-160-120	1/2"	3"	4-3/4"

Métrica

Código	Diámetro	Largo de corte	Largo total
ST-1-161-200	2.0mm	22mm	45mm
ST-1-161-205	2.5mm	25mm	51mm
ST-1-161-210	3.0mm	32mm	57mm
ST-1-161-215	3.5mm	35mm	64mm
ST-1-161-220	4.0mm	35mm	64mm
ST-1-161-225	4.5mm	41mm	70mm
ST-1-161-230	5.0mm	45mm	76mm
ST-1-161-235	5.5mm	45mm	76mm
ST-1-161-240	6.0mm	51mm	83mm
ST-1-161-245	6.5mm	51mm	83mm
ST-1-161-250	7.0mm	54mm	89mm
ST-1-161-255	8.0mm	60mm	95mm
ST-1-161-260	9.0mm	64mm	102mm
ST-1-161-265	10.0mm	73mm	114mm
ST-1-161-270	12.0mm	76mm	121mm

Broca Zanco Recto Flauta Recta de Carburo



Flauta recta
Zanco recto
Tamaño métrico
Corte a la derecha
Punta en ángulo de 140°
Fabricada de carburo sólido
Ideal para metales endurecidos y abrasivos



Tubo plástico



Tubo plástico



Código	Diámetro	Diámetro décimas	Largo de corte	Largo total
ST-1-160-300	3 mm	0.1181	7/8"	1 - 7/8"
ST-1-160-310	4 mm	0.1575	1 - 1/16"	2 - 1/8"
ST-1-160-320	5 mm	0.1969	1 - 3/16"	2 - 1/4"
ST-1-160-330	6 mm	0.2362	1 - 5/16"	2 - 7/16"
ST-1-160-340	8 mm	0.3150	1 - 5/8"	2 - 13/16"
ST-1-160-350	10 mm	0.3937	1 - 7/8"	3 - 1/4"
ST-1-160-360	12 mm	0.4724	2 - 1/8"	3 - 5/8"

PERFORACIÓN

Broca de Centro de Carburo

Grano de carburo sub-micrónico sólido C-2 grado premium con 10% Cobalto
Punta en ángulo de 60°
Corte a la derecha
Zanco recto
Acabado brillante
2 flautas
Para acero, fundición, materiales ferrosos y no ferrosos



Tubo plástico



Código	#	Diámetro cuerpo	Diámetro punta	Largo total
ST-1-600-010	1	1/8"	3/64"	1-1/2"
ST-1-600-020	2	3/16"	5/64"	1-7/8"
ST-1-600-030	3	1/4"	7/64"	2"
ST-1-600-040	4	5/16"	1/8"	2-1/8"
ST-1-600-050	5	7/16"	3/16"	2-3/4"
ST-1-600-060	6	1/2"	7/32"	3"



Drill Doctor

MARCA ESPECIALIZADA EN AFILADO DE BROCAS

Piedra de Diamante para Afilar

Ahorra tiempo al reparar brocas muy dañadas o rotas
SA-190-0665: afila brocas de carburo
SA-190-0670: afila brocas de acero alta velocidad, cobalto con recubrimiento de titanio y brocas para mampostería

COMPATIBLE CON:



Código	Grano	Tipo de grano	Compatible con modelo
SA-190-0665	100	Grueso	XP, 500X, 750X
SA-190-0670	180	Fino	XP, 500X, 750X



Afilador de Brocas



115 V

Ideal para afilar brocas de carburo, cobalto, acero de alta velocidad, óxido negro, recubiertas de TiN, brocas giro estándar y de mampostería
Mordazas de sujeción largas que sostienen las brocas con mayor precisión, y las guías de las mordazas eliminan la torsión de la mandíbula en brocas pequeñas
Incluye piedra de diamante para afilar y portabrocas giro estándar
Cable de alimentación de 6 pies



SA-190-0650



SA-190-0660



SA-190-0655

DISPONIBLE EN:

Piedras de diamante para afilar
VER PÁG. 140

Código	Modelo	Uso	Rango de broca	Grados de afilado
SA-190-0650	XP	Ligero	3/32" a 1/2"	118°
SA-190-0655	500X	Mediano	3/32" a 1/2"	118°-135°
SA-190-0660	750X	Pesado	3/32" a 3/4"	115°-140°





Plantilla para Uniones Ocultas



Permite unir esquinas, bordes y superficies
Cuerpo fabricado en plástico ABS para mayor resistencia
Postes autocentranes que permiten una alineación precisa
Guías de perforación de acero endurecido para mayor durabilidad



Código	Para perforaciones de:	Esesor de:
ST-5-152-200	1/4", 5/16", 3/8"	1/2" a 1-1/2"

Juego de Plantilla para Uniones Ocultas



Permite unir esquinas, bordes y superficies
Cuerpo fabricado en plástico ABS para mayor resistencia
Postes autocentranes que permiten una alineación precisa
Guías de perforación de acero endurecido para mayor durabilidad
Incluye: 1 plantilla, 3 brocas para madera de 1/4", 5/16" y 3/8", 3 topes de profundidad de 1/4", 5/16" y 3/8", 1 llave hexagonal, 6 centradores para taquetes, 62 taquetes de madera, 1 pegamento para madera de 59 ml, 1 instructivo manual, estuche de plástico



Código	Para perforaciones de:	Esesor de:
ST-5-152-215	1/4", 5/16", 3/8"	1/2" a 1-1/2"

Juego de Plantilla para Orificios Ocultos



Ideal para uniones a 90° con tornillo oculto
Mediciones incorporadas en plantilla
Perfecta para armar y reparar
Perforaciones precisas y fáciles de ocultar
Compacto para usar en lugares estrechos
Diseño versátil para proyectos sobre la marcha
Marcas de referencia incorporadas para marcar el grosor de la tabla y configurar la plantilla rápidamente
Incluye: 1 plantilla, 1 broca para madera escalonada 3/8", 1 punta Torx T20 x 6" magnética, 1 tope de profundidad 3/8", 1 llave hexagonal, 1 instructivo manual



Código	Esesor de:	Zanco
ST-5-152-205	1/2" a 1-1/2"	1/4"

Juego de Plantilla para Orificios Ocultos Doble Guía



Ideal para uniones a 90° con tornillo oculto
Mediciones incorporadas
Perfecta para armar y reparar
Perforaciones precisas y fáciles de ocultar
Compacto para usar en lugares estrechos
Diseño versátil para proyectos sobre la marcha
Marcas de referencia incorporadas para marcar el grosor de la tabla y configurar la plantilla rápidamente
Incluye: 1 plantilla, 1 tope de profundidad 3/8", 1 broca para madera escalonada 3/8", 1 conexión de cambio rápido, 1 punta torx T20 x 6" magnética, 1 punta torx T20 x 3" magnética, 1 llave hexagonal, 10 taquetes, tornillos torx T20 (10 de 25 mm, 10 de 30 mm, 10 de 40 mm, 10 de 50 mm, 10 de 64 mm), 1 instructivo manual



Código	Esesor de:	Zanco
ST-5-152-210	1/2" a 1-1/2"	1/4"

Juego de Plantilla para Orificios Ocultos Uso Pesado



Cuerpo de aluminio que aumenta la rigidez y reduce la flexión
Abrazadera de acero para una sujeción perfecta
Perforaciones precisas y fáciles de ocultar
Incluye: 1 plantilla, 1 estructura en L para montaje, 2 tornillos de elevación de profundidad M4-6 mm, 1 tope de profundidad 3/8", 1 broca para madera escalonada 3/8", 1 punta torx T20 x 6" magnética, 1 llave hexagonal, 4 tornillos para montaje, 2 arandelas, 2 tornillos de cabeza hueca, 24 taquetes, tornillos T20 torx de: 1" 25 piezas, 1-1/4" 25 piezas, 1-1/2" 25 piezas, 2" 25 piezas, 1 instructivo manual

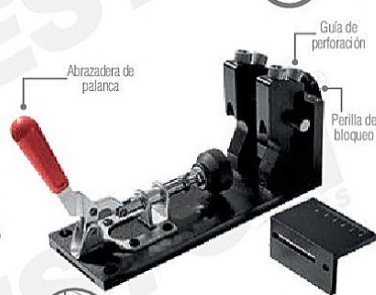

Código	Esesor de:	Zanco
ST-5-152-225	1/2" a 1-1/2"	1/4"

Juego de Tornillos para Orificios Ocultos



Tipo torx cabeza plana y de arandela
Recubiertos de zinc
Perfectos para unir piezas de trabajo, asegurando una sujeción segura
Estuche de almacenamiento de plástico reutilizable
Incluye tornillos T20 torx de: 1" 150 piezas, 1-1/4" 150 piezas, 1-1/2" 100 piezas, 2" 75 piezas, 2-1/2" 75 piezas, 1,25" tornillos T20 torx rosca fina 150 piezas, 1 punta torx T20 x 3" magnética, 1 punta torx T20 x 6" magnética



Código	Contenido
ST-5-152-220	700 tornillos

Broca Portainsero C-300 Recta con Zanco Cónico

Incluye: llave hexagonal para portainsero



Código	Para inserto	Profundidad	Longitud cuerpo	Longitud total	Cono	Pipe tap	Anillo para broca compatible
SA-190-0010	45/64" a 15/16"	2-3/4"	3-7/8"	9-5/32"	MT 3	1/8"	SA-190-0510
SA-190-0020	31/32" a 1-3/8"	3-3/8"	4-1/2"	9-25/32"	MT 3	1/8"	SA-190-0510
SA-190-0030	1-3/16" a 1-3/8"	3-3/8"	4-1/2"	9-25/32"	MT 3	1/8"	SA-190-0520
SA-190-0040	1-13/32" a 1-7/8"	4-3/4"	6"	12-9/16"	MT 4	1/4"	SA-190-0520
SA-190-0050	1-29/32" a 2-9/16"	5-1/8"	6-1/2"	13-1/16"	MT 4	1/4"	SA-190-0520

Broca Portainsero C-300 Recta Extra Larga con Zanco Cónico

Incluye: llave hexagonal para portainsero



Código	Para inserto	Profundidad	Longitud cuerpo	Longitud total	Cono	Pipe tap	Anillo para broca compatible
SA-190-0060	45/64" a 15/16"	7-7/8"	9-39/64"	13-5/32"	MT 3	1/8"	SA-190-0510
SA-190-0070	55/64" a 15/16"	7-7/8"	9-39/64"	13-5/32"	MT 3	1/8"	SA-190-0510
SA-190-0080	31/32" a 1-3/8"	8-1/2"	10-15/64"	13-25/32"	MT 3	1/8"	SA-190-0510
SA-190-0090	1-3/16" a 1-3/8"	8-1/2"	10-15/64"	13-25/32"	MT 3	1/8"	SA-190-0520
SA-190-0100	1-13/32" a 1-7/8"	9-1/2"	11-5/8"	16-1/16"	MT 4	1/4"	SA-190-0520
SA-190-0110	1-29/32" a 2-9/16"	10-1/2"	12-5/8"	17-1/16"	MT 4	1/4"	SA-190-0520
SA-190-0120	2-1/2" a 3-1/2"	12-1/2"	15-5/16"	20-15/16"	MT 5	1/2"	-

Broca Portainsero C-300 Espiral con Zanco Cónico

Incluye: llave hexagonal para portainsero



Código	Para inserto	Profundidad	Longitud cuerpo	Longitud total	Cono	Pipe tap	Anillo para broca compatible
SA-190-0130	45/64" a 15/16"	4-3/4"	5-7/8"	11-5/32"	MT 3	1/8"	SA-190-0510
SA-190-0140	55/64" a 15/64"	4-3/4"	5-7/8"	11-5/32"	MT 3	1/8"	SA-190-0510
SA-190-0150	31/32" a 1-3/8"	5-3/8"	6-1/2"	12-25/32"	MT 4	1/8"	SA-190-0510
SA-190-0160	1-3/16" a 1-3/8"	5-3/8"	6-1/2"	12-25/32"	MT 4	1/4"	SA-190-0520

Broca Portainsero C-300 Recta con Zanco Recto

Incluye: llave hexagonal para portainsero



Código	Para inserto	Profundidad	Longitud cuerpo	Longitud total	Pipe tap	Tornillo para broca compatible
SA-190-0300	45/64" a 15/16"	2-5/8"	3-7/8"	6-7/8"	1/8"	SA-190-0600
SA-190-0310	31/32" a 1-3/8"	3-3/8"	4-1/2"	8"	1/8"	SA-190-0610

Broca Portainsero C-300 Recta Extra Larga con Zanco Recto

Incluye: llave hexagonal para portainsero



Código	Para inserto	Profundidad	Longitud cuerpo	Longitud total	Pipe tap	Anillo para broca compatible
SA-190-0320	45/64" a 15/16"	6-5/8"	7-7/8"	10-7/8"	1/8"	SA-190-0600
SA-190-0330	31/32" a 1-3/8"	7-3/8"	8-1/2"	12"	1/8"	SA-190-0610
SA-190-0340	1-13/32" a 1-7/8"	8-1/4"	9-1/2"	13-1/2"	1/4"	-

Anillo para Broca Portainsero

Código	Diámetro interior	Diámetro exterior	Espesor
SA-190-0500	3/4"	1-3/4"	7/8"
SA-190-0510	1"	2-1/8"	1-1/8"
SA-190-0520	1-1/4"	2-1/2"	1-3/8"

Tornillo para Broca Portainsero

Código	Medida
SA-190-0600	45/64" a 15/16"
SA-190-0610	31/32" a 1-3/8"
SA-190-0620	1-29/32" a 2-9/16"

Inserto C-300 con TiAlN



TiAlN



Cortador Anular

Zanco tipo Weldon de 3/4" (excepto * ST-5-530-160 que es de 1-1/4")
 Capacidad de perforación superior, rápida y precisa
 Gran durabilidad



Acero alla velocidad

Titanio con revestimiento de nitruro de titanio

AAV

TiN



Tubo plástico

Fraccional

Código	Conector	Diámetro	Compatible con broca porrtainserto
SA-190-0710	33/64" a 11/16"	9/16"	
SA-190-0720	33/64" a 11/16"	5/8"	
SA-190-0722	45/64" a 15/16"	23/32"	SA-190-0010
SA-190-0730	45/64" a 15/16"	3/4"	SA-190-0060
SA-190-0733	45/64" a 15/16"	13/16"	SA-190-0130
SA-190-0740	45/64" a 15/16"	7/8"	SA-190-0300
SA-190-0750	45/64" a 15/16"	15/16"	SA-190-0320
SA-190-0760	13/32" a 1-3/8"	1"	
SA-190-0765	31/32" a 1-3/8"	1-1/64"	
SA-190-0770	31/32" a 1-3/8"	1-1/16"	
SA-190-0780	31/32" a 1-3/8"	1-1/8"	
SA-190-0790	31/32" a 1-3/8"	1-3/16"	
SA-190-0800	31/32" a 1-3/8"	1-1/4"	
SA-190-0810	31/32" a 1-3/8"	1-5/16"	
SA-190-0820	31/32" a 1-3/8"	1-3/8"	
SA-190-0830	1-13/32" a 1-7/8"	1-7/16"	
SA-190-0833	1-13/32" a 1-7/8"	1-15/26"	SA-190-0040
SA-190-0840	1-13/32" a 1-7/8"	1-1/2"	SA-190-0100
SA-190-0850	1-13/32" a 1-7/8"	1-5/8"	SA-190-0340
SA-190-0860	1-13/32" a 1-7/8"	1-3/4"	
SA-190-0870	1-13/32" a 1-7/8"	1-7/8"	
SA-190-0880	1-29/32" a 2-9/16"	2"	
SA-190-0890	1-29/32" a 2-9/16"	2-1/8"	SA-190-0050
SA-190-0900	1-29/32" a 2-9/16"	2-1/4"	SA-190-0110
SA-190-0910	1-29/32" a 2-9/16"	2-3/8"	
SA-190-0920	1-29/32" a 2-9/16"	2-1/2"	
SA-190-0930	2-1/2" a 3-1/2"	3-1/4"	

Métrico

Código	Conector	Diámetro	Broca porta inserto compatible
SA-190-1150	33/64" a 11/16"	14 mm	
SA-190-1160	33/64" a 11/16"	16 mm	
SA-190-1170	45/64" a 15/16"	20 mm	SA-190-0010
SA-190-1180	45/64" a 15/16"	22 mm	SA-190-0060
SA-190-1190	45/64" a 15/16"	24 mm	SA-190-0130
SA-190-1200	13/32" a 1-3/8"	26 mm	SA-190-0300
SA-190-1210	13/32" a 1-3/8"	28 mm	SA-190-0320
SA-190-1220	13/32" a 1-3/8"	32 mm	
SA-190-1230	13/32" a 1-3/8"	35 mm	SA-190-0040
SA-190-1240	1-13/32" a 1-7/8"	36mm	SA-190-0100
SA-190-1250	1-13/32" a 1-7/8"	40 mm	SA-190-0340

AAV	Titanio	Diámetro	Profundidad de corte	Flautas
ST-5-530-111	ST-5-530-111-T	1/2"	1"	4
ST-5-530-113	ST-5-530-113-T	9/16"	1"	4
ST-5-530-116	ST-5-530-116-T	5/8"	1"	5
ST-5-530-119	ST-5-530-119-T	11/16"	1"	5
ST-5-530-121	ST-5-530-121-T	3/4"	1"	6
ST-5-530-124	ST-5-530-124-T	13/16"	1"	6
ST-5-530-127	ST-5-530-127-T	7/8"	1"	6
	ST-5-530-130-T	15/16"	1"	6
ST-5-530-133	ST-5-530-133-T	1"	1"	6
ST-5-530-136	ST-5-530-136-T	1-1/16"	1"	8
	ST-5-530-138-T	1-1/8"	1"	8
	ST-5-530-140-T	1-3/16"	1"	8
ST-5-530-145	ST-5-530-145-T	1-1/4"	1"	8
	ST-5-530-147-T	1-5/16"	1"	8
	ST-5-530-149-T	1-3/8"	1"	10
	ST-5-530-151-T	1-1/2"	1"	10
*ST-5-530-160		2-5/8"	1"	14
ST-5-530-211	ST-5-530-211-T	1/2"	2"	4
ST-5-530-213	ST-5-530-213-T	9/16"	2"	4
ST-5-530-216	ST-5-530-216-T	5/8"	2"	5
ST-5-530-218		11/16"	2"	4
	ST-5-530-219-T	11/16"	2"	5
ST-5-530-221	ST-5-530-221-T	3/4"	2"	6
	ST-5-530-224-T	13/16"	2"	6
ST-5-530-227	ST-5-530-227-T	7/8"	2"	6
ST-5-530-229	ST-5-530-229-T	15/16"	2"	6
ST-5-530-233	ST-5-530-233-T	1"	2"	6
ST-5-530-237	ST-5-530-237-T	1-1/16"	2"	8
ST-5-530-239	ST-5-530-239-T	1-1/8"	2"	8
ST-5-530-242	ST-5-530-242-T	1-3/16"	2"	8
ST-5-530-245	ST-5-530-245-T	1-1/4"	2"	8
ST-5-530-248	ST-5-530-248-T	1-5/16"	2"	8
ST-5-530-251	ST-5-530-251-T	1-3/8"	2"	8
	ST-5-530-254-T	1-7/16"	2"	10
ST-5-530-257	ST-5-530-257-T	1-1/2"	2"	9
ST-5-530-260	ST-5-530-260-T	1-9/16"	2"	10
ST-5-530-263	ST-5-530-263-T	1-5/8"	2"	10
ST-5-530-269	ST-5-530-269-T	1-3/4"	2"	10
ST-5-530-275	ST-5-530-275-T	1-7/8"	2"	10
ST-5-530-281	ST-5-530-281-T	2"	2"	12
	ST-5-530-283-T	2-1/8"	2"	12
	ST-5-530-285-T	2-1/4"	2"	12
	ST-5-530-287-T	2-3/8"	2"	12
	ST-5-530-289-T	2-1/2"	2"	14

Perno Botador para Cortador Anular



Perforación precisa



Protección contra sobrecalentamiento



Gran estabilidad y confianza

TALADROS MAGNÉTICOS

110 V 3/4"
BROQUERO WELDON



RoHS

CE

Ver página 205

ST-5-530-905	1/4 x 3"
ST-5-530-915	1/4 x 4"



#sipacificoindustrial



Servicios Industriales DEL PACÍFICO

www.sipacifico.com.mx



Cortador Anular TCT Tipo HF

Ideal para láminas delgadas de metal
Dientes de carburo de tungsteno
Material del cortador: acero aleado
Baja presión de corte
Aplicaciones: láminas de metal SS41, hierro fundido, fibra de vidrio
Profundidad de perforación: 5 mm de espesor
Longitud efectiva: 12 mm de profundidad
Incluye llave de ajuste



Código	Diámetro	Zanco
ST-5-530-309	3/4"	3/8"
ST-5-530-312	13/16"	3/8"
ST-5-530-317	1-1/16"	3/8"
ST-5-530-320	1-1/8"	3/8"
ST-5-530-326	1-3/8"	3/8"



Ejemplo de uso



Código	Diámetro	Zanco
ST-5-530-300	9/16"	3/8"
ST-5-530-303	5/8"	3/8"
ST-5-530-306	11/16"	3/8"



Resorte expulsor de forma segura la viruta cuando finaliza el corte



Tubo plástico

Cortador Anular TCT Tipo HP

Trabajo pesado, alto rendimiento
Ideal para tubos de metal
Dientes de carburo de tungsteno
Material del cortador: acero aleado
Baja presión de corte
Aplicaciones: láminas de metal SS41 y SUS304, hierro fundido, perfil de acero
Profundidad de perforación: 5 mm de espesor
Longitud efectiva: 42 mm de profundidad
Incluye llave de ajuste



Código	Diámetro	Zanco
ST-5-530-350	13/16"	3/8"



Ejemplo de uso



Resorte expulsor de forma segura la viruta cuando finaliza el corte



Tubo plástico

PERFORACIÓN RPM PARA CORTADORES ANULARES MEDIDA / MATERIAL

Medida	Acero 500 N/mm ²	Acero 750 N/mm ²	Acero 900 N/mm ²	Acero 1,200 N/mm ²	Acero 1,400 N/mm ²	Acero Inoxidable	Aluminio	Fierro Vaciado	Cobre
7/16"	663	530	344	265	185	318	981	477	1,061
17/32"	612	489	318	244	171	293	905	440	979
19/32"	568	454	295	227	159	272	841	409	909
5/8"	530	424	275	212	148	254	785	381	848
21/32"	497	397	258	198	139	238	736	358	795
11/16"	468	374	243	187	131	224	692	337	748
45/64"	442	353	229	176	123	212	654	318	707
3/4"	418	335	217	167	117	201	619	301	670
25/32"	397	318	206	159	111	190	588	286	636
13/16"	378	303	197	151	106	181	560	272	606
7/8"	361	289	188	144	101	173	535	260	578
59/64"	345	276	179	138	96	166	512	249	553
15/16"	331	265	172	132	92	159	490	238	530
1"	318	254	165	127	89	152	471	229	509
1-1/32"	306	244	159	122	85	146	452	220	489
1-1/16"	294	235	153	117	82	141	436	212	471
1-1/8"	284	227	147	113	79	136	420	204	454
1-9/64"	274	219	142	109	76	131	406	197	439
1-3/16"	265	212	137	106	74	127	392	190	424
1-7/32"	256	205	133	102	71	123	379	184	410
1-1/4"	248	198	129	99	69	119	368	179	397
1-5/16"	241	192	125	96	67	115	356	173	385
1-11/32"	234	187	121	93	65	112	346	168	374
1-3/8"	227	181	118	90	63	109	336	163	363
1-27/64"	221	176	114	88	61	106	327	159	353
1-7/16"	215	172	111	86	60	103	318	154	344
1-1/2"	209	167	108	83	58	100	309	150	335

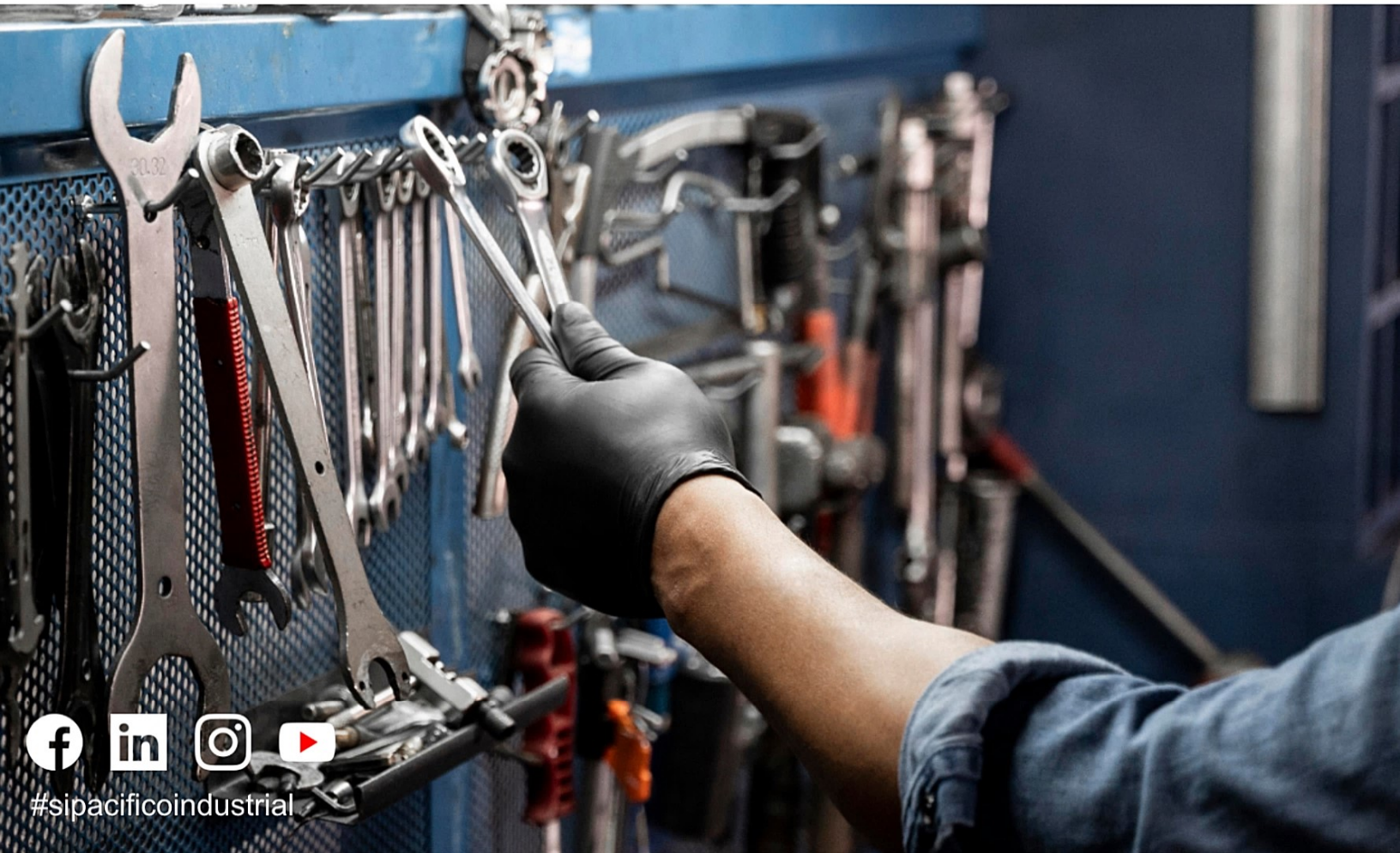

#sipacificoindustrial



Servicios Industriales DEL PACIFICO

ALIADO ESTRATEGICO DE LA INDUSTRIA

Teléfono: +52 (663) 107 7832

Correo: contacto@sipacifico.com.mx

Dirección
Ciruelo s/n, Col. Granja Santa Cecilia C.P 21386
Mexicali Baja California